

# W □ L De-energized Tap Changer Technical Instructions

---

HM0.154.602

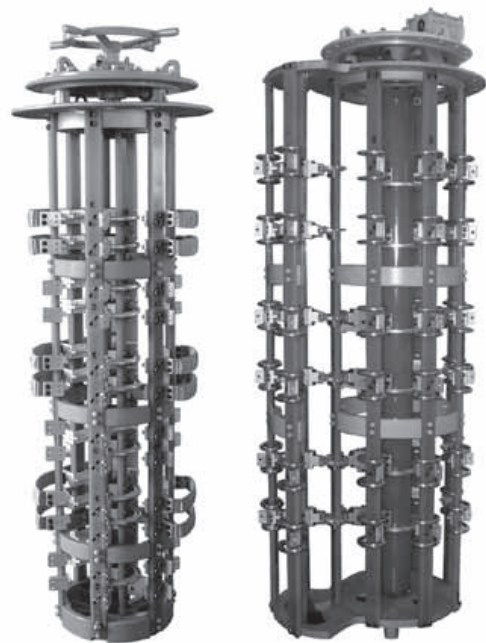

**Shanghai Huaming Power Equipment Co.,Ltd.**

## General

1. General.....	2
2. Technical specifications.....	2
3. Type designation.....	3
3.1. Type explanation.....	3
3.2. Tap changer basic connection diagram.....	4
4. Terms and definitions.....	6
4.1. Rated through-current.....	6
4.2. Short circuit current test.....	7
4.3. Service condition of tap changers.....	7
4.4. Internal insulation of tap changer.....	7
4.5. Tap changer insulation to earth.....	13
4.6. Tap changer mounting method.....	13
5. Special design.....	13
6. Operation method.....	14
6.1. Hand wheel operation.....	14
6.2. Manual drive mechanism at side.....	14
6.3. Motor drive unit at side.....	14
7. Position indicator.....	15
7.1. HMC-3W De-energized tap changer position indicator.....	15
8. Accessories.....	15
9. Appendix.....	16

## 1. General

Type W□L Off-Circuit Tap Changer (herein referred as tap changer) is of in-tank structure and without separate oil compartment. It is mounted to transformer tank by a tap changer head flange.

By the operation method, tap changer can be divided into motor driving at man position, and manual drive mechanism operating at man position as well as hand wheel manual operation on the top.

By the dimensions of contact circle diameter, tap changer can be divided into type A, type B, type D and Type E.

Tap changer head flange can be either bell type mounting or standard tank mounting type.

By tap changer internal structure, it can be divided into linear, single-bridging, double-bridging, Y-D change-over, series-parallel change-over and reversing. Refer to table 2 for the basic connection methods code and Fig. 2 for connection schematic diagrams. For special design, please contact HM technical department.

## 2. Technical specifications

It is designed and produced according to IEC60214-1 Standard and GB100230.1. Tap changer technical data is listed in Table 1 below.

**Table 1 W□L DETC TECHNICAL DATA**

Item	Type		WSL, WDL							
1	No. of Phases		3-phase, single-phase							
2	Max. rated through current(A)		600	800	1000	1200	1600	2000	2400	3000
3	Short-circuit current test (kA)	Thermal(3s)	9	12	15	15	20	24	26	30
		Dynamic(Peak)	22.5	30	37.5	37.5	50	60	65	75
4	Rated frequency (Hz)		50 or 60							

	Insulation to ground (kV)	The highest voltage for equipment	12	72.5	126	145	170	252
			I/III	I/III	I/III	I/III	I/III	I/III
		Rated separate source AC withstand voltage(kV/50Hz, 1min))	35	140	230	275	325	460
		Rated lightning impulse withstand voltage (kV,1.2/50 $\mu$ s)	75	325	550	650	750	1050
6	Internal insulation	Refer to Table 4						
7	Contact circle diameter	Type A: Ø350 Type B: Ø500 Type D: Ø600 Type E: Ø750						
8	Max. operating positions	Max. 5 for type A, Max. 5 for type B, Max. 11 for type D, Max. 17 for type E						
9	Mechanical life	Not less than 20,000 operations for manual driving Not less than 100,000 operations for motor driving						
10	Weight (kg)	Type A			Type B, D, E			
		Max:100			Max: 195			

**Remark: The tap changer can be designed and produced according to special requirements, please contact with HM Technical Department.**

### 3. Type designation

#### 3.1.Type explanation

Due to the different combinations of number of phases, maximum rated through current, the highest voltage for equipment and connection, type W□L off-circuit tap changer comes with various models. Hence, the type designation shall provide all the above all the above technical parameters and below is detailed explanation in Fig. 1.

W □ L □ - □ □ / □ - □ X □ (□) □

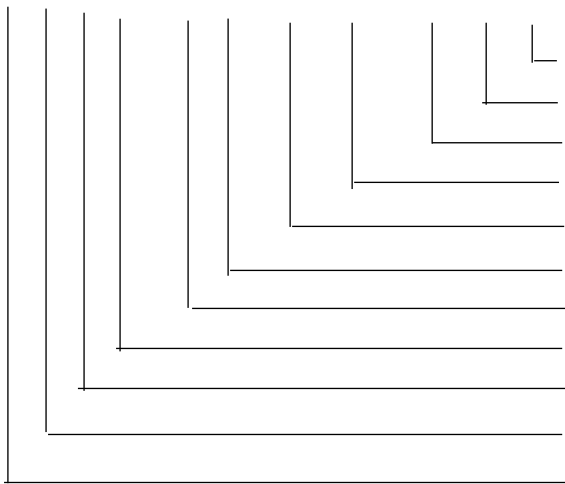

- Installation
- Contact circle diameter (A/B/D/E)
- Operating positions
- Contact pitch
- The highest voltage for equipment (kV)
- Connection (Y-for neutral point. D-for any connection)
- Max. rated through current (A)
- Basic connection method (Refer to table 1)
- Cage Type
- No. of Phases(D for I phase, S for three phases)
- Off-circuit tap changer

**Fig. 1 Tap Changer Model Explanation**

**Table 2 Tap Changer Basic Connection Method and Mark**

Code	IV	V	VI	VII	VIII	II
Connection	Linear	Single-bridging	Y-D change-over	Double-bridging	Series-paralle change-over	Reversing

### 3.2. Tap changer basic connection diagram

Different transformer winding corresponds to different tap changer basic connection diagram. Fig.2 shows commonly used connections. It can also be specially designed as per customer requirement.

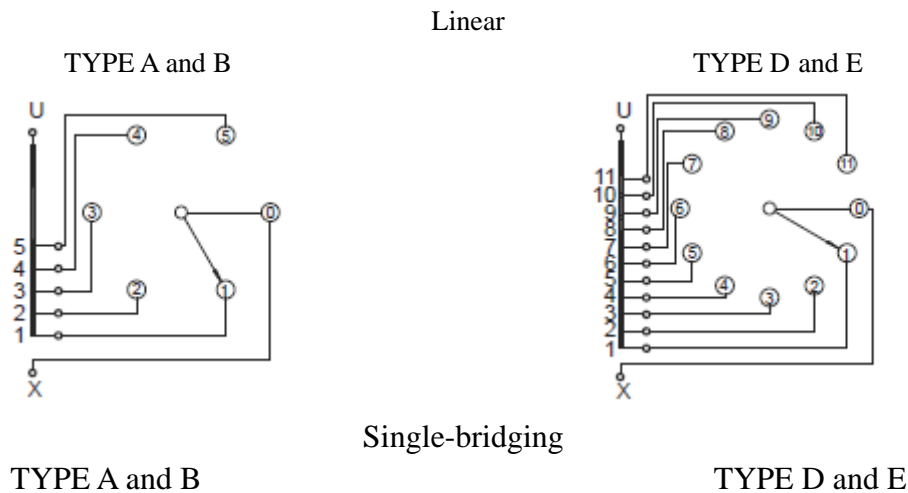

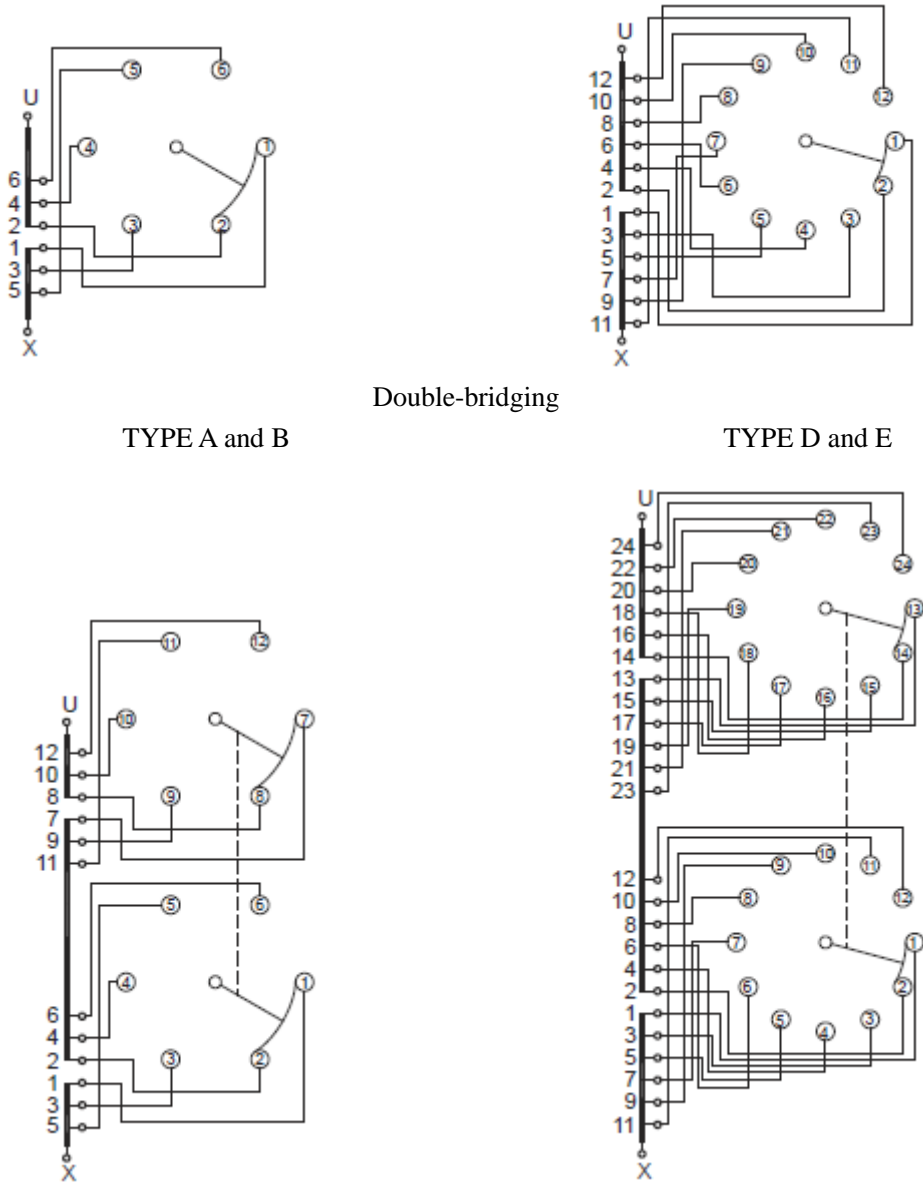

Double-bridging

TYPE A and B

TYPE D and E

**Fig. 2 Tap Changer Basic Connection Diagram**

Series-parallel change-over

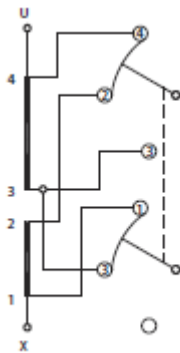

Y-D change-over

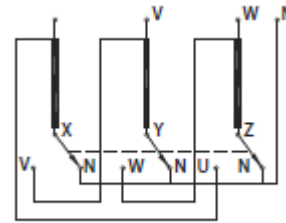

Reversing

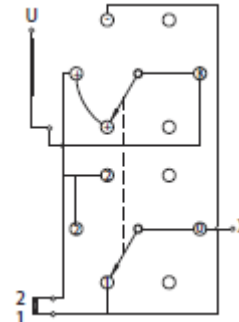
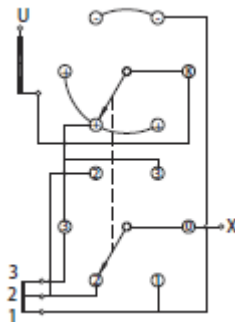

Tap position	1	2	3	4	5
Regulating position	+2	+1	0	-1	-2
Connection type	$\textcircled{K} - \oplus$	$\textcircled{K} - \oplus$	$\textcircled{K} - \oplus$	$\textcircled{K} - \ominus$	$\textcircled{K} - \ominus$
Connection type	$\textcircled{0} - \textcircled{1}$	$\textcircled{0} - \textcircled{2}$	$\textcircled{0} - \textcircled{3}$	$\textcircled{0} - \textcircled{2}$	$\textcircled{0} - \textcircled{3}$

Tap position	1	2	3
Regulating position	+1	0	-1
Connection type	$\textcircled{K} - \oplus$	$\textcircled{K} - \oplus$	$\textcircled{K} - \ominus$
Connection type	$\textcircled{0} - \textcircled{1}$	$\textcircled{0} - \textcircled{2}$	$\textcircled{0} - \textcircled{2}$

**Fig. 2 Tap Changer Basic Connection Diagram (Continued)**

## 4. Terms and definitions

### 4.1. Rated through-current

Rated through current  $I_u$ : The current flowing through the tap changer toward the external circuit, which can be carried continuously while meeting the requirement.

The maximum rated through current  $I_{um}$ : The highest rated through current for which the tap changer is designed for and which forms the basis for all current related tests.

## 4.2. Short circuit current test

According to IEC 60214-1: 2003, all contacts continuously carrying the current shall be able to withstand 2s ( $\pm 10\%$ ) short circuit test current without melting, deformation or mechanical damage. Meanwhile the starting peak current value shall be 2.5 ( $\pm 5\%$ ) times of the root means square value of rated short circuit test current. Refer the short circuit test current values to Table 1 Type WSL Series of Off-Circuit Tap Changer Technical Data.

## 4.3. Service condition of tap changers

**4.3.1.** Service temperature range of the tap changer in oil is  $-25^{\circ}\text{C} \sim +100^{\circ}\text{C}$ .

**4.3.2.** Service temperature of standard designed OLTC is  $-25^{\circ}\text{C}$  to  $40^{\circ}\text{C}$ . If the temperature exceeds the range of standard ( $-25^{\circ}\text{C}$  to  $40^{\circ}\text{C}$ ), please specify when ordering. To meet the ordering requirements and comply with operating environment, if the requested service temperature is out of the range of  $-60^{\circ}\text{C}$  to  $40^{\circ}\text{C}$ , the material and accessories of the OLTC will be specially designed and selected.

**4.3.3.** Perpendicular deflection between ground and tap changer after being mounting on transformer shall be less than 2%.

**4.3.4.** There shall be no serious dust, explosive gas or corrosive gas on service site.

## 4.4. Internal insulation of tap changer

The internal insulation of WSL off-circuit tap changer is mainly depending on the rated withstand voltage of actual required gradient. Voltage gradient of tap changer internal insulation usually occurs during the transformer lightning impulse test and inductive withstand voltage test. It changes with the tap positions. Refer to table 3 for the internal insulations and fig. 3 for basic connection diagram and insulation distance mark. It must be checked when selecting the tap changer to ensure the conformity with insulation requirement.

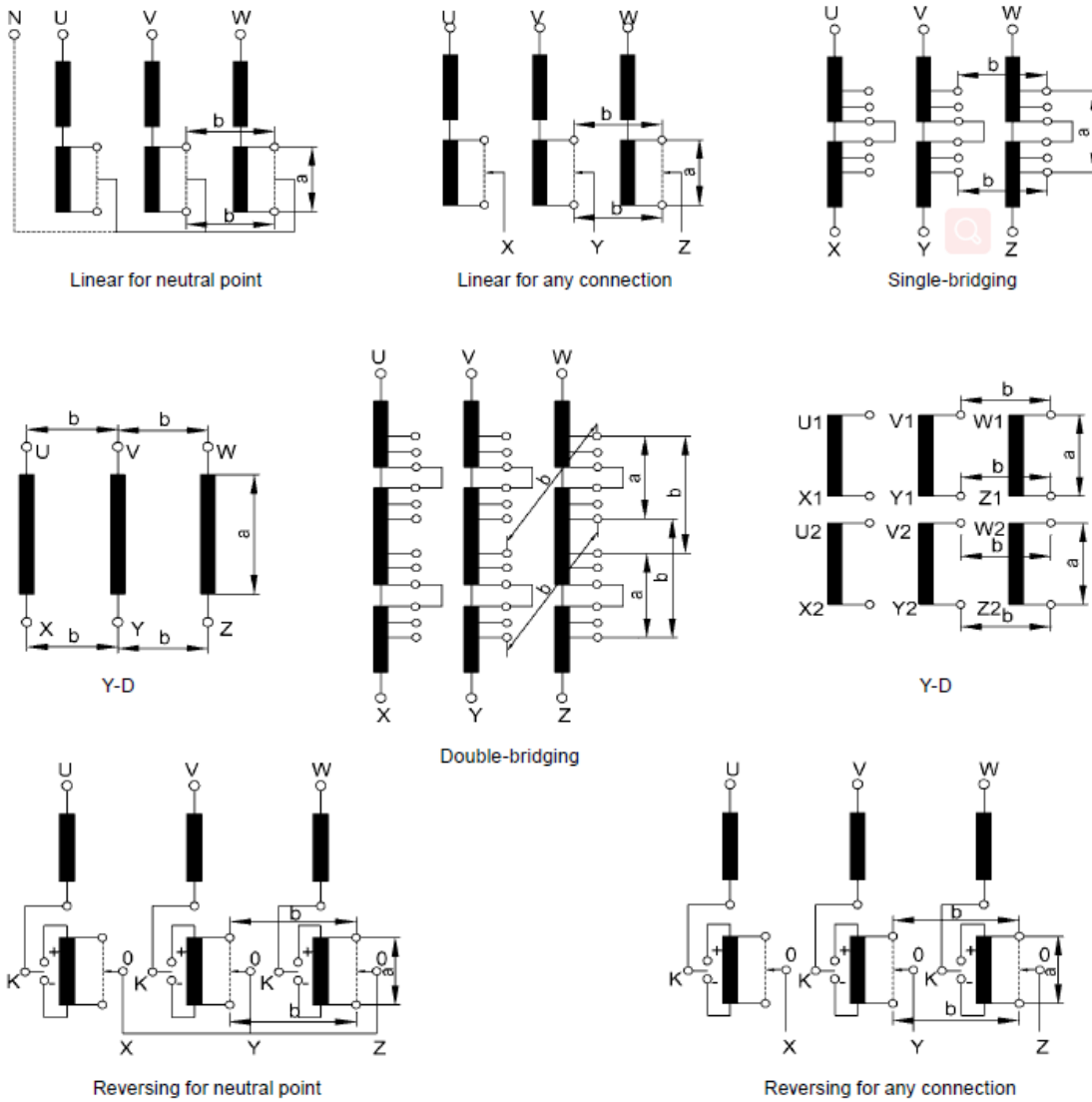

a: Between max. and min. taps of the same phase

b: Between any winding taps of different phases or between start and end of the same tap winding for double-bridging

**Table 3: Tap changer Internal Insulation Level (Continued 1) (Unit: Kv)**

Basic Connection mode Contact circle diameter		Single-bridging (V)					
		A Ø 350mm			B Ø 500mm		
Highest Voltage for equipment	Insulation gap	Tap position	Power frequency withstand voltage 50Hz/1min(Kv)	Impulse test voltage (Kv) 1.2/50us	Tap position	Power frequency withstand voltage 50Hz/1min(Kv)	Impulse test voltage (Kv) 1.2/50us
12	a	2-5	65	158	2-5	90	258
	b	-	50	125	-	50	125
72.5	a	2-5	65	158	2-5	90	258
	b	-	140	325	-	140	325
126	a	2-5	65	158	2-5	90	258
	b	-	230	550	-	230	550
170	a	-	-	-	2-5	90	258
	b	-	-	-	-	325	750
252	a	-	-	-	2-5	90	258
	b	-	-	-	-	-	-

D Ø 600mm				E Ø 750mm			
Highest Voltage for equipment	Insulation gap	Tap position	Power frequency withstand voltage 50Hz/1min(Kv)	Impulse test voltage (Kv) 1.2/50us	Tap position	Power frequency withstand voltage 50Hz/1min(Kv)	Impulse test voltage (Kv) 1.2/50us
72.5	a	2-5	185	450	2-5	275	650
		6-11	50	125	6-11	115	280
		-	-	-	12-17	38	75
126	b	-	140	325	-	140	325
		2-5	185	450	2-5	275	650
		6-11	50	125	6-11	115	280
170	b	-	-	-	12-17	38	75
		-	230	550	-	230	550
		2-5	185	450	2-5	275	650
252	a	2-5	185	450	2-5	275	650
	b	-	-	-	-	-	-

**Table 3: Tap changer Internal Insulation Level (Continued 2) (Unit: Kv)**

Basic Connection mode		Double-bridging (VII)					
Contact circle diameter		A Ø 350mm			B Ø 500mm		
Highest Voltage for equipment	Insulation gap	Tap position	Power frequency withstand voltage 50Hz/1min(Kv)	Impulse test voltage (Kv) 1.2/50us	Tap position	Power frequency withstand voltage 50Hz/1min(Kv)	Impulse test voltage (Kv) 1.2/50us
12	a	2-5	65	158	2-5	90	258
	b	-	50	125	-	50	125
	c	-	38	95	-	38	95
72.5	a	2-5	65	158	2-5	90	258
	b	-	140	325	-	140	325
	c	-	65	158	-	65	158
126	a	2-5	65	158	2-5	90	258
	b	-	230	550	-	230	550
	c	-	70	170	-	70	170

D Ø 600mm				E Ø 750mm			
Highest Voltage for equipment	Insulation gap	Tap position	Power frequency withstand voltage 50Hz/1min(Kv)	Impulse test voltage (Kv) 1.2/50us	Tap position	Power frequency withstand voltage 50Hz/1min(Kv)	Impulse test voltage (Kv) 1.2/50us
72.5	a	2-5	185	450	2-5	275	650
		10-11	50	125	6-11	115	280
		-	-	-	12-17	38	75
	b	-	140	325	-	140	325
		-	65	158	-	65	158
126	a	2-5	185	450	2-5	275	650
		10-11	50	125	6-11	115	280
		-	-	-	12-17	38	75
	b	-	230	550	-	230	550
		c	-	70	170	-	70

**Table 3: Tap changer Internal Insulation Level (Continued 3) (Unit: Kv)**

Basic Connection mode Contact circle diameter		Series-parallel (VIII)			
		A Ø 350mm		B Ø 500mm	
Highest Voltage for equipment	Insulation gap	Power frequency withstand voltage 50Hz/1min (Kv)	Impulse test voltage (Kv) 1.2/50us	Power frequency withstand voltage 50Hz/1min (Kv)	Impulse test voltage (Kv) 1.2/50us
12	a	65	158	90	258
	b	50	125	90	125
72.5	a	-	-	90	258
	b	-	-	140	325
126	a	-	-	90	258
	b	-	-	230	550
170	a	-	-	90	258
	b	-	-	-	-
252	a	-	-	90	258
	b	-	-	-	-

**D Ø 600mm**
**E Ø 750mm**

Highest Voltage for equipment	Insulation gap	Power frequency withstand voltage 50Hz/1min (Kv)	Impulse test voltage (Kv) 1.2/50us	Power frequency withstand voltage 50Hz/1min (Kv)	Impulse test voltage (Kv) 1.2/50us
72.5	a	185	450	275	650
	b	140	325	140	325
126	a	185	450	275	650
	b	230	550	230	550
170	a	185	450	275	650
	b	-	-	-	-
252	a	185	450	275	650
	b	-	-	-	-

Basic Connection mode Contact circle diameter		Y-D (VI)			
		A Ø 350mm		B Ø 500mm	
Highest Voltage for equipment	Insulation gap	Power frequency withstand voltage 50Hz/1min (Kv)	Impulse test voltage (Kv) 1.2/50us	Power frequency withstand voltage 50Hz/1min (Kv)	Impulse test voltage (Kv) 1.2/50us
12	a	50	125	140	325
	b	50	125	50	125
72.5	a	-	-	140	325
	b	-	-	140	325

**Table 3: Tap changer Internal Insulation Level (Continued 4) (Unit: Kv)**

D Ø 600mm					
Highest Voltage for equipment	Insulation gap	Power frequency withstand voltage 50Hz/1min (Kv)	Impulse test voltage (Kv) 1.2/50us		
12	a	275	650		
	b	50	125		
72.5	a	275	650		
	b	140	325		
126	a	275	650		
	b	230	550		

Basic Connection mode		Y Reversing for neutral point (II Y)					
Contact circle diameter		A Ø 350mm			B Ø 500mm		
Highest Voltage for equipment	Insulation gap	Tap position	Power frequency withstand voltage 50Hz/1min(Kv)	Impulse test voltage (Kv) 1.2/50us	Tap position	Power frequency withstand voltage 50Hz/1min(Kv)	Impulse test voltage (Kv) 1.2/50us
12	a	2-5	65	158	2-5	90	258
	b	-	50	125	-	50	125
72.5	a	2-5	65	158	2-5	90	258
	b	-	70	170	-	70	170
126	a	2-5	65	158	2-5	90	258
	b	-	90	258	-	90	258
170	a	-	-	-	2-5	90	258
	b	-	-	-	-	105	240
252	a	-	-	-	2-5	90	258
	b	-	-	-	-	118	270

D Ø 600mm				E Ø 750mm			
Highest Voltage for equipment	Insulation gap	Tap position	Power frequency withstand voltage 50Hz/1min(Kv)	Impulse test voltage (Kv) 1.2/50us	Tap position	Power frequency withstand voltage 50Hz/1min(Kv)	Impulse test voltage (Kv) 1.2/50us
72.5	a	2-5	185	450	2-5	275	650
		6-11	50	125	6-11	115	280
		-	-	-	12-17	38	75
		-	70	170	-	70	170
126	a	2-5	185	450	2-5	275	650
		6-11	50	125	6-11	115	280
		-	-	-	12-17	38	75
		b	-	90	258	-	90
170	a	2-5	185	450	2-5	275	650
	b	-	325	750	-	325	750

**Table 3: Tap changer Internal Insulation Level (Continued 5) (Unit: Kv)**

252	a	2-5	185	450	2-5	275	650
	b	-	-	-	-	-	-

### 4.5. Tap changer insulation to earth

The insulation level of tap changer to earth, namely, the insulation of the live parts of tap changer and the ground, is determined by the AC power frequency one-minute voltage test value and impulse voltage test value. It is related to the tap winding position of transformer, voltage regulation range and voltage regulation method, the connection method and structure arrangement of winding, and the rated voltage of transformer winding, which is determined by the insulation level of transformer winding to ground.

The insulation level to earth of tap changer is selected from the standard specified value (refer to Table 4) by IEC60214 and GB10230.1 according to the highest working voltage  $U_m$  of tap changer so that insulation value as low as possible can meet the entire range of use.

**Table 4 Tap changer insulation level to earth (Unit:Kv)**

The highest voltage for equipment (kV)	Rated separate source AC withstand voltage (kV/50Hz, 1min)	Rated lightning impulse withstand voltage (kV, 1.2/50 $\mu$ s)
12	35	75
72.5	140	325
126	230	550
170	325	750
252	460	1050

### 4.6. Tap changer mounting method

W $\square$ L de-energized tap changer is a cage type without oil compartment. It can be mounted in the transformer tank directly. There should be an installation flange on the transformer tank in order to fix tap changer. There are two mounting methods of standard installation and bell type according to the different transformer structure. Please refer to Appendix.

## 5. Special design

This technical data is including relevant parameters of regular tap changers. Special design will be considered according to the customers' special requirements, such as big current rating or special connections. Please contact us for special requirements with technical data.

## 6. Operation method

### 6.1. Hand wheel operation

Drive the main shaft of tap changer directly through hand wheel on the top of tap changer to realize the tap changing.

### 6.2. Manual drive mechanism at side

The manual drive mechanism is mounted on the side of the transformer tank. Tap changer is driven by the drive shaft and gear box. The dimension and installation are shown in the Appendix.

### 6.3. Motor drive unit at side

Using CMA7 and SHM-D motor drive to realize the motor driving for tap changer. Refer to Appendix of Motor drive unit dimension and table 5 for technical data. Motor drive unit is mounted on the side of transformer tank, driving tap changer by shaft and gear box. It is suitable for tap changer required frequently tap changing or remote operation. Refer to Appendix of installation drawing.

**Table 5: Motor drive unit technical parameters**

Motor drive unit		CMA7	
Motor	Rated power (W)	750	1100
	Rated voltage (V)	380/3AC	
	Rated current (A)	2.0	2.8
	Rated frequency (Hz)	50 or 60	
	Rated speed (r.p.m)	1400	
Rated torque on drive shaft (Nm)		18	26
Revolution the drive shaft per switching operation		33	
Revolution of the hand crank per switching operation		33	
Running time per switching operation (S)		About 5	
Max. operation positions		107	
Voltage for control circuit and heater circuit (V)		220/AC	
Heater power(W)		50	
A.C. voltage test to ground (kV/50Hz, 1min)		2	
Protective degree		IP66	
Mechanical endurance (operations)		Not less than 800,00	
Motor drive unit		SHM-D	
Step Motor	Rated voltage (V)	220/AC	
	Rated current (A)	6	
	Rated frequency (Hz)	50 or 60	

Rated torque on drive shaft (Nm)	35
Revolution the drive shaft per switching operation	33
Revolution of the hand crank per switching operation	33
Automatic operation time of each step (S)	Approx. 5
Max. operation positions	107
Insulation grade (kV/1min,50Hz)	2
Protective degree	IP66

## 7. Position indicator

### 7.1.HMC-3W De-energized tap changer position indicator

HMC-3W DETC position indicator is designed for CMA7 motor drive unit. It can be used to indicate the DETC position remote room.

HMC-3W technical parameters:

Working voltage: 220V AC

Power frequency: 50 Hz

Maximum operation positions: 39

Environment temperature: -10°C ~ +40°C

**Note: for special power supply, please inform when ordering.**

## 8. Accessories

Bevel gearbox is applicable for connection of horizontal shaft of tap changer and vertical shaft of the motor drive unit, by which transferring the driving torque from motor drive unit to tap changer, its overall dimensions is shown in appendix 29.

## 9. Appendix

- Appendix 1 600-1000A Linear regulation, overall dimension
- Appendix 2 600-1000A 252kV Linear regulation, overall dimension
- Appendix 3 600-1000A Single-bridging regulation, overall dimension
- Appendix 4 600-1000A Y-D regulation, overall dimension
- Appendix 5 600-1000A Double-bridging regulation, overall dimension
- Appendix 6 600-1000A Series-parallel regulation, overall dimension
- Appendix 7 600-1000A Reversing regulation, overall dimension
- Appendix 8 600-1000A 252kV reversing regulation, overall dimension
- Appendix 9 1000-2000A Reversing regulation, overall dimension
- Appendix 10 Installation flange for standard tank type cover, overall dimension
- Appendix 11 Installation flange for bell type tank cover, overall dimension
- Appendix 12 Ground motor drive (manual), Type A for standard tank, head flange dimensions Appendix 13 Ground motor drive (manual), type B, D, E for standard tank, head flange dimensions Appendix 14 Top cover hand wheel type A for standard tank, head flange dimension
- Appendix 15 Top cover hand wheel type B, D, E for standard tank, head flange dimension Appendix 16 Ground motor drive (manual), Type A for bell type tank, head flange dimensions Appendix 17 Ground motor drive (manual), type B, D for bell type tank, head flange dimensions Appendix 18 Ground motor drive (manual), type E for bell type tank, head flange dimensions Appendix 19 Top cover hand wheel type A for bell type tank, head flange dimension
- Appendix 20 Top cover hand wheel type B, D for bell type tank, head flange dimension
- Appendix 21 Top cover hand wheel type E for bell type tank, head flange dimension
- Appendix 22 Type A bell type supporting flange, installation drawing
- Appendix 23 Type B, D bell type supporting flange, installation drawing
- Appendix 24 Type E bell type supporting flange, installation drawing
- Appendix 25 Tap changer terminal overall dimension
- Appendix 26 Ground motor drive, Tap changer installation drawing
- Appendix 27 Ground manual drive, Tap changer installation drawing
- Appendix 28 Bevel gear, over dimensions
- Appendix 29 Side-manual operation, overall dimension
- Appendix 30 SHM-D Motor drive unit, overall dimension
- Appendix 31 SHM-K Remote controller, overall dimension

## Appendix 1 600-1000A Linear regulation, overall dimension

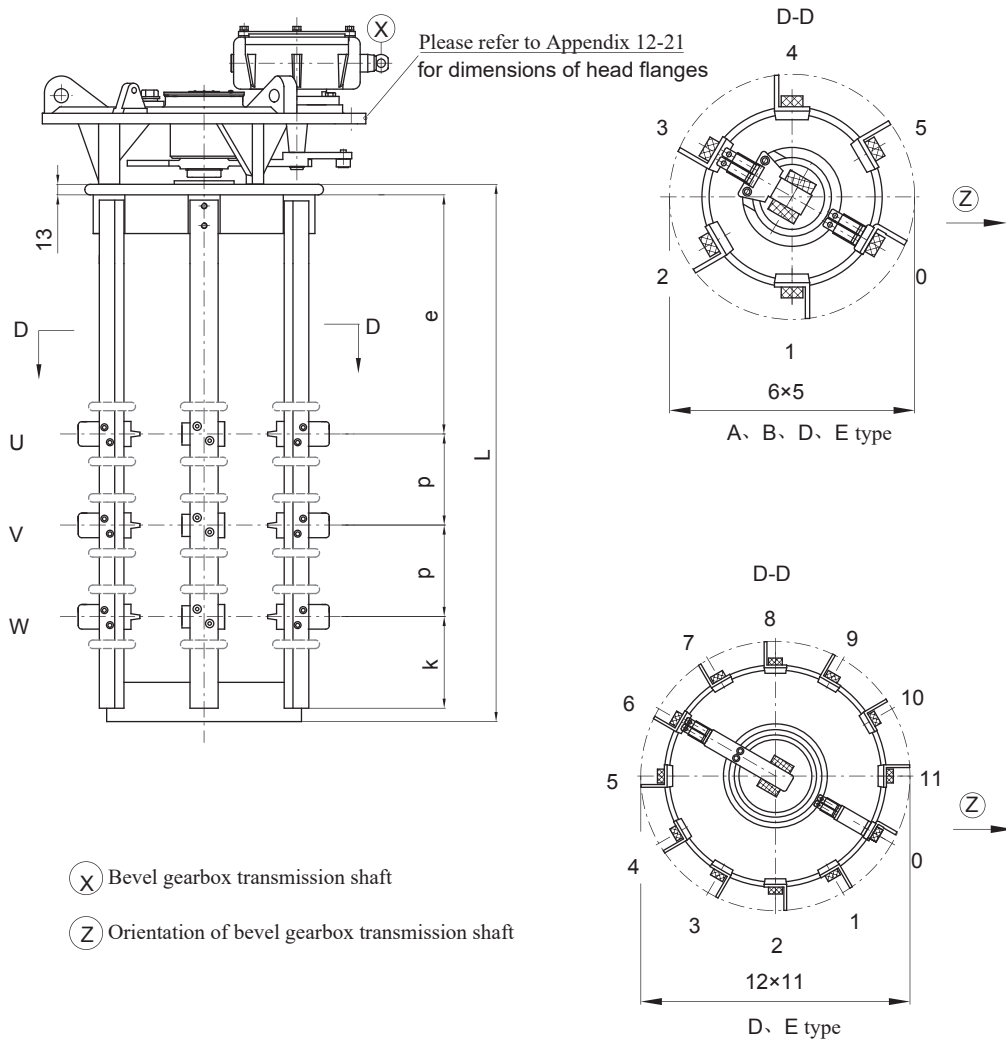

- Note:
- ① Generally type A is applicable to the current of less than 800A
  - ② Connect dimension. Please refer to Appendix 20
  - ③ A, B, D and E type cage outer diameters:  $\Phi 350\text{mm}$ 、 $\Phi 500\text{mm}$ 、 $\Phi 600\text{mm}$ 和 $\Phi 750\text{mm}$

Conection Highest Voltage for equipment	Y				D			
	e	p	k	L	e	p	k	L
12kV	200	130	135	630	200	130	135	630
72.5kV	340	130	145	780	340	280	145	1080
126kV	470	170	155	1000	470	410	155	1480

Unit :mm

## Appendix 2 600-1000A 252kV Linear regulation, overall dimension

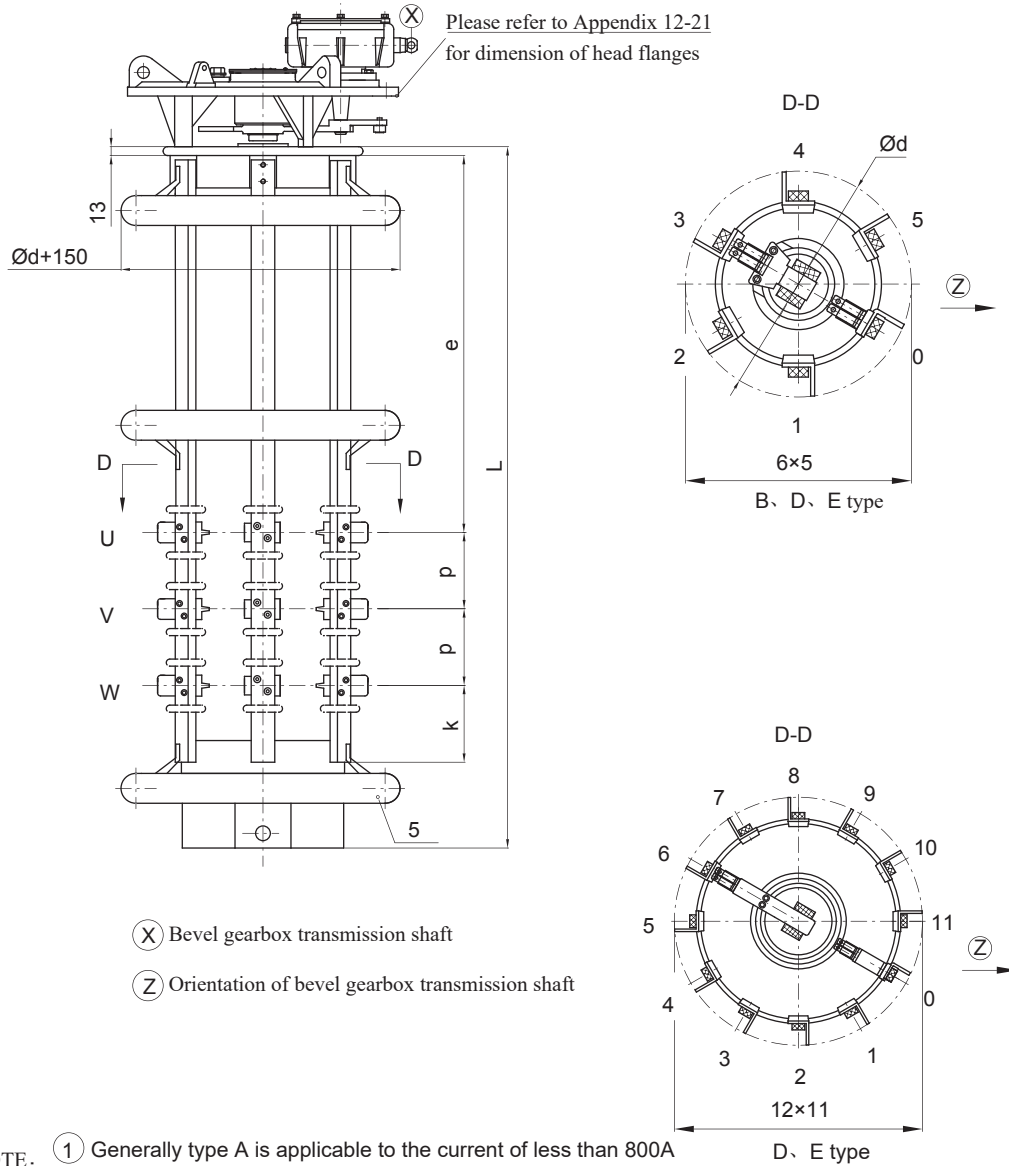

Conection	Y			
	e	p	k	L
Highest Voltage for equipment 252kV	980	170	155	1690

Unit:mm

### Appendix 3 600-1000A Single-bridging regulation, overall dimension

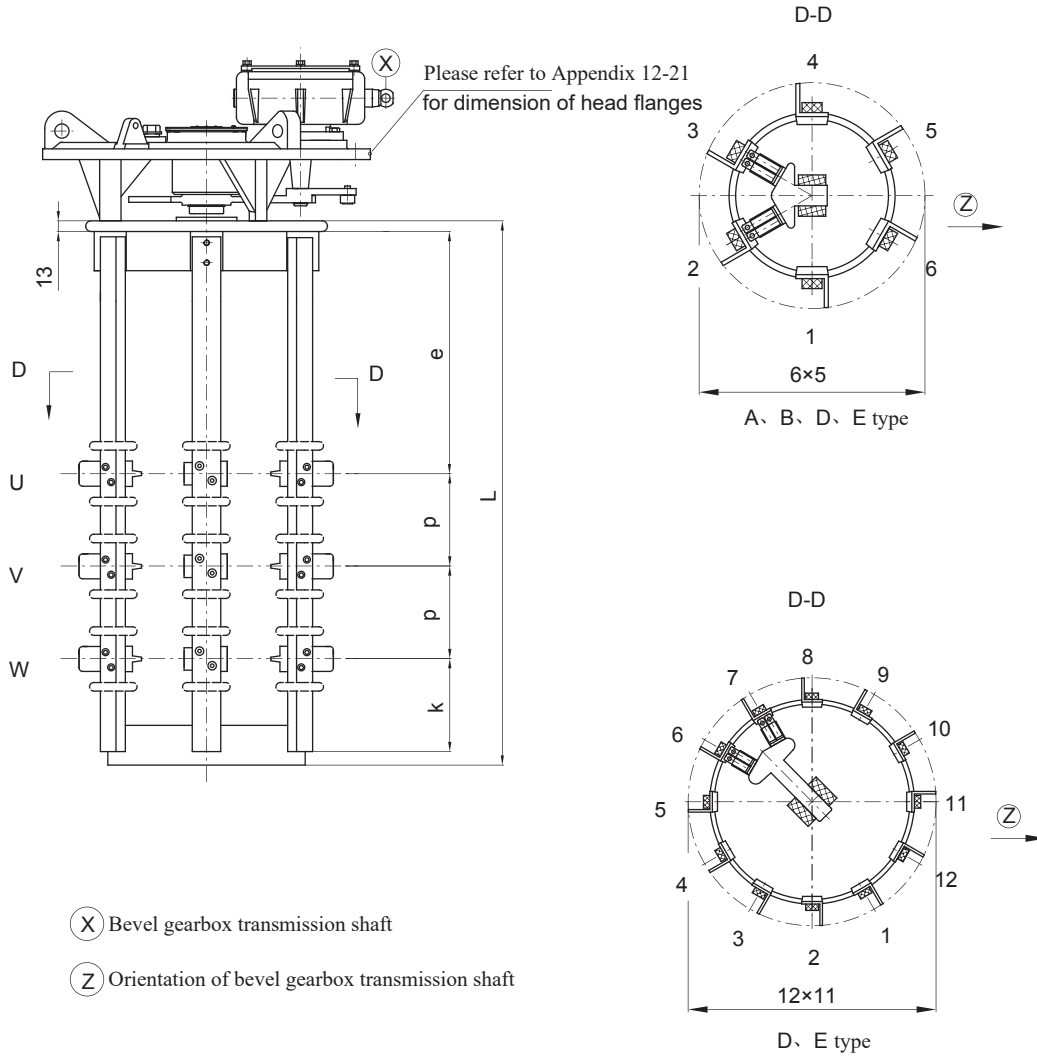

- Note:
- ① Generally type A is applicable to the current of less than 800A
  - ② Connect dimension. Please refer to Appendix 20
  - ③ A、 B、 D and E type cage outer diameters:  $\Phi 350\text{mm}$ 、  $\Phi 500\text{mm}$ 、  $\Phi 600\text{mm}$  and  $\Phi 750\text{mm}$

Highest Voltage for equipment	e	p	k	L
12kV	200	130	135	630
72.5kV	340	280	145	1080
126kV	470	410	155	1480

Unit : mm

## Appendix 4 600-1000A Y-D regulation, overall dimension

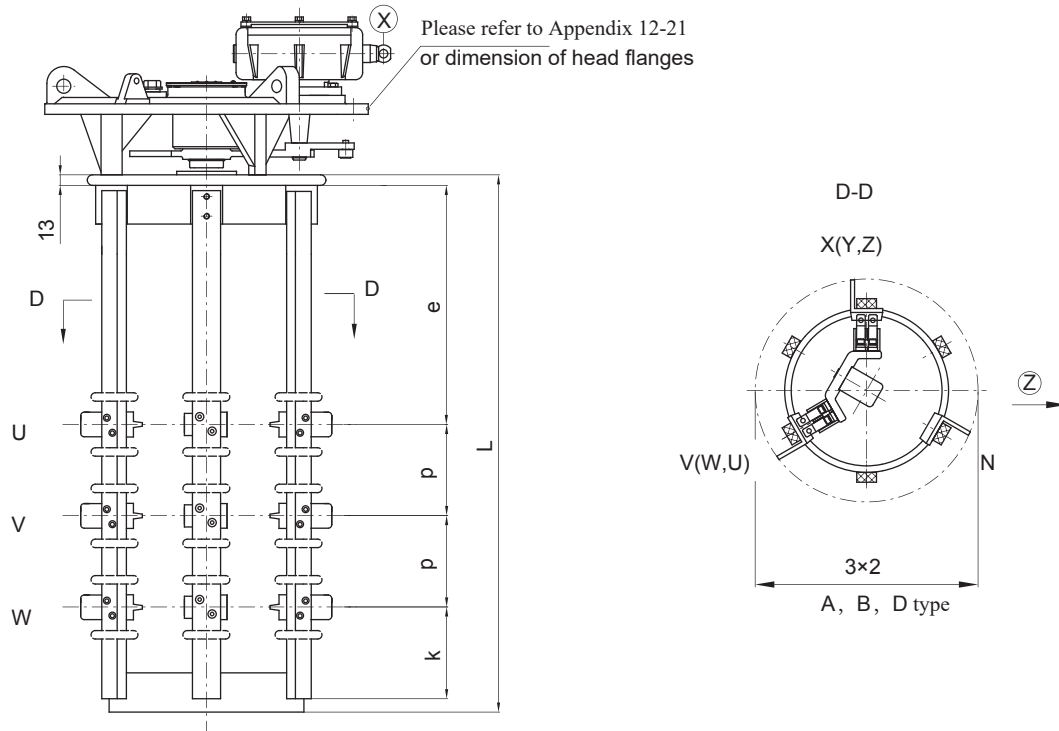

(X) Bevel gearbox transmission shaft

(Z) Orientation of bevel gearbox transmission shaft

- Note:
- ① Generally type A is applicable to the current of less than 800A
  - ② Connect dimension. Please refer to Appendix 20
  - ③ A、B、D and E type cage outer diameters:  $\Phi 350\text{mm}$ 、 $\Phi 500\text{mm}$ 、 $\Phi 600\text{mm}$  and  $\Phi 750\text{mm}$

Highest Voltage for equipment	e	p	k	L
12kV	200	130	135	630
72.5kV	340	280	145	1080
126kV	470	410	155	1480

Unit:mm

## Appendix 5 600-1000A Double-bridging regulation, overall dimension

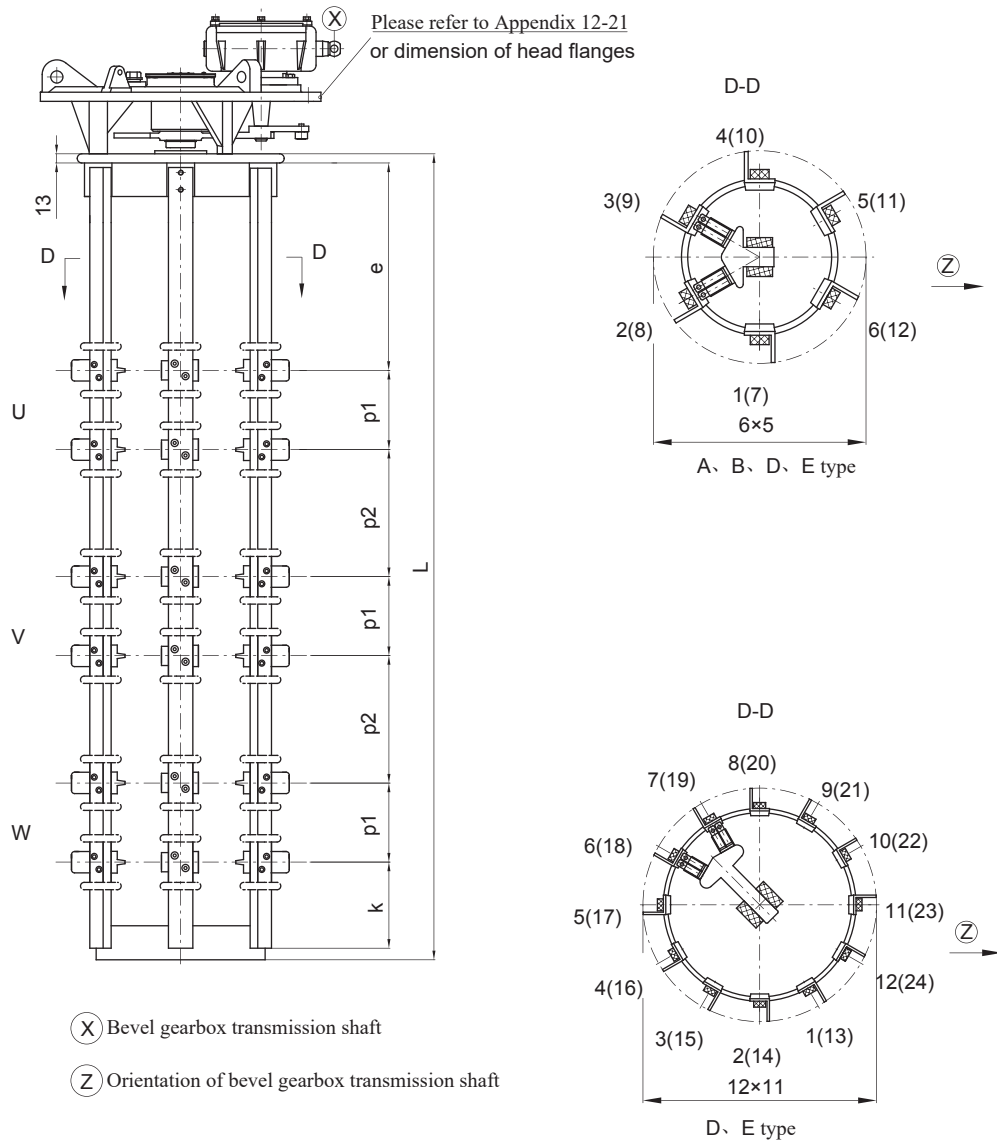

- 注: ① Generally type A is applicable to the current of less than 800A
- ② Connect dimension. Please refer to Appendix 20
- ③ A、B、D and E type cage outer diameters:  $\Phi 350\text{mm}$ 、 $\Phi 500\text{mm}$ 、 $\Phi 600\text{mm}$  and  $\Phi 750\text{mm}$

Highest Voltage for equipment	e	p1	p2	k	L
12 kV	200	120	150	125	1020
72.5 kV	340	160	280	145	1560
126 kV	470	170	410	155	1990

Unit:mm

## Appendix 6 600-1000A Series-parallel regulation, overall dimension

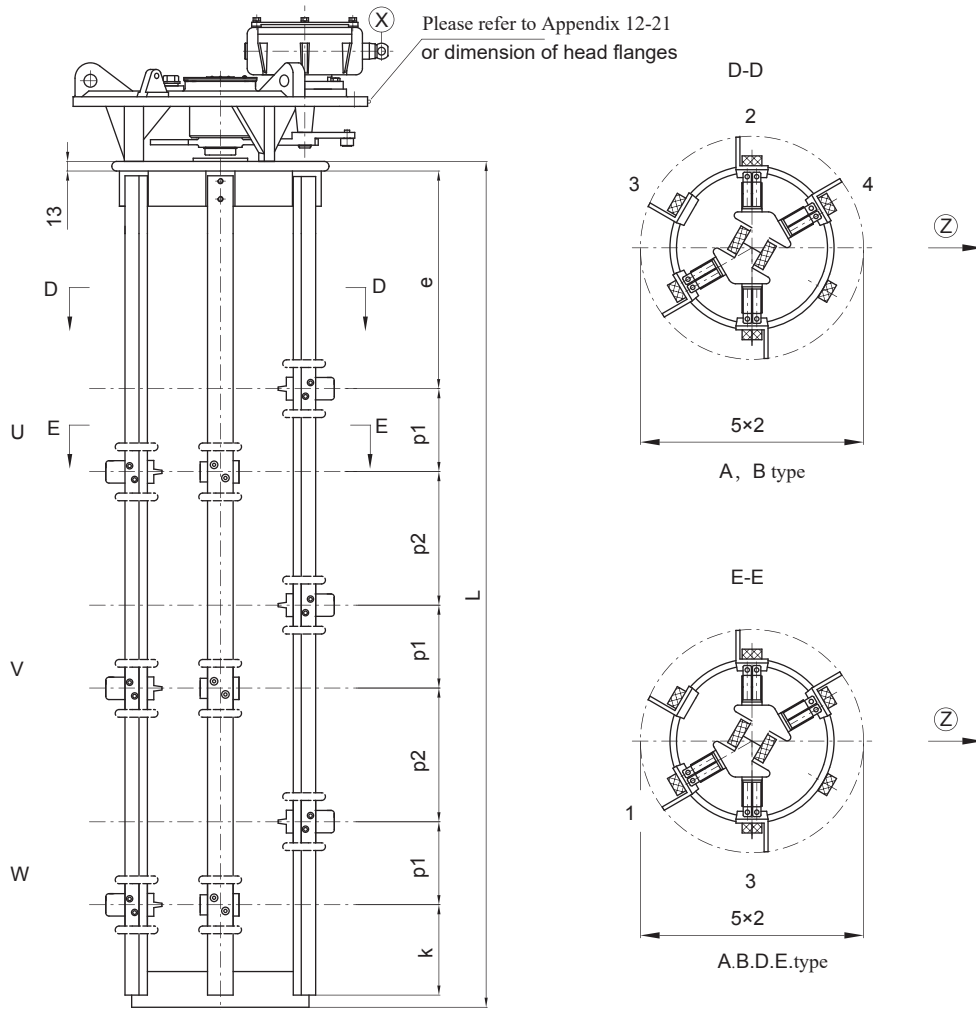

- (X) Bevel gearbox transmission shaft
- (Z) Orientation of bevel gearbox transmission shaft

- Note:
- (1) Generally type A is applicable to the current of less than 800A
  - (2) Connect dimension. Please refer to Appendix 20
  - (3) A、 B、 D and E type cage outer diameters:  $\Phi 350\text{mm}$ 、  $\Phi 500\text{mm}$ 、  $\Phi 600\text{mm}$  and  $\Phi 750\text{mm}$

Highest Voltage for equipment	e	p1	p2	k	L
12 kV	200	120	150	125	1020
72.5 kV	340	160	280	145	1560
126 kV	470	170	410	155	1990

Unit:mm

## Appendix 7 600-1000A Reversing regulation, overall dimension

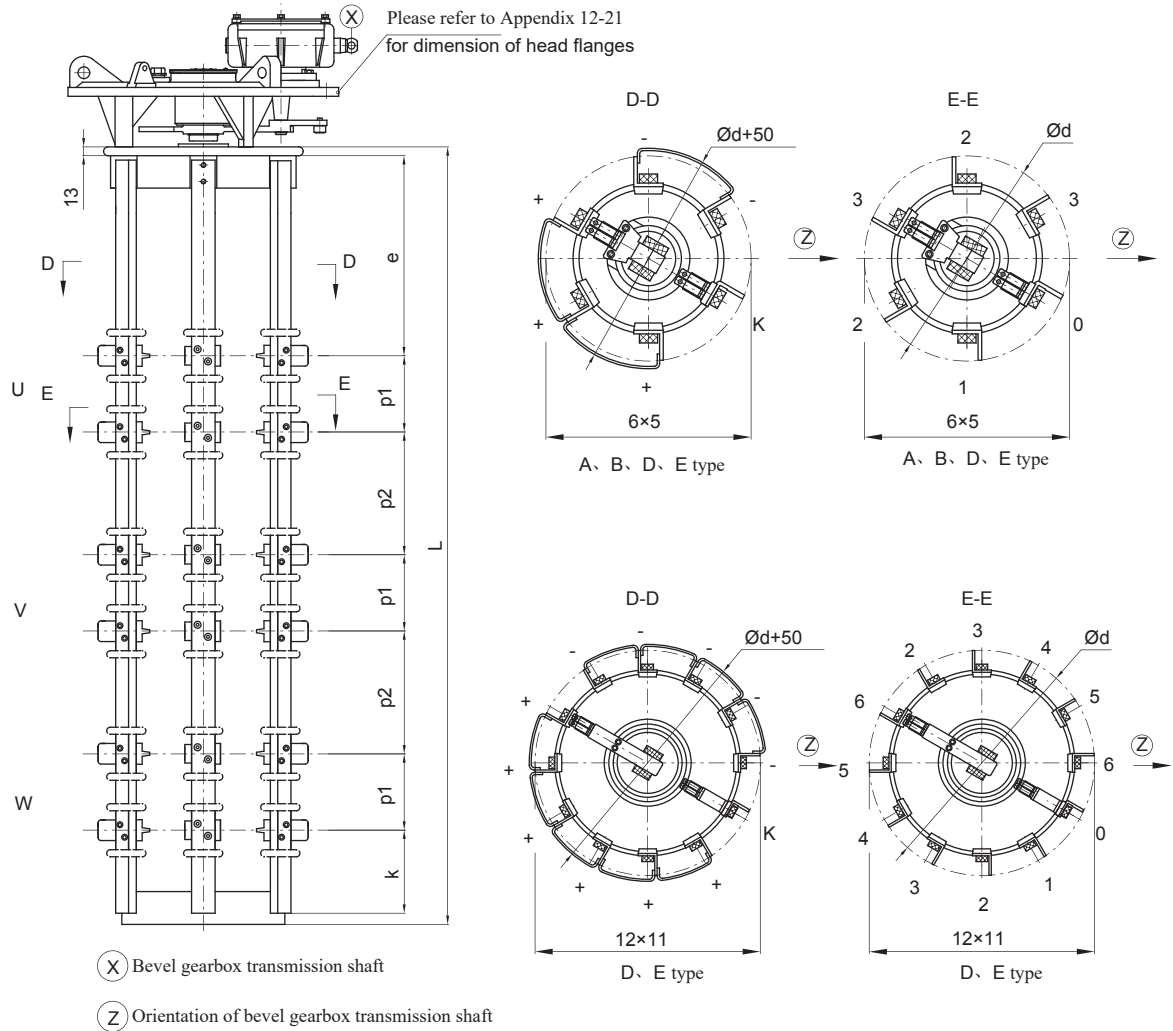

- 注:
- ① Generally type A is applicable to the current of less than 800A
  - ② Connect dimension. Please refer to Appendix 20
  - ③ Regularly Huaming connection "+" and "+", "-" and "-", as shown "D-D", Others connection by customers
  - ④ A、B、D and E type cage outer diameters:  $\Phi 350\text{mm}$ 、 $\Phi 500\text{mm}$ 、 $\Phi 600\text{mm}$  and  $\Phi 750\text{mm}$

Connection	Y					D				
	e	p1	p2	k	L	e	p1	p2	k	L
Highest Voltage for equipment										
12kV	170	120	120	125	930	200	120	150	125	1020
72.5kV	340	135	160	150	1250	340	160	280	145	1560
126kV	470	170	170	155	1510	470	170	410	155	1990

Unit :mm

## Appendix 8 600-1000A 252kV Reversing regulation, overall dimension

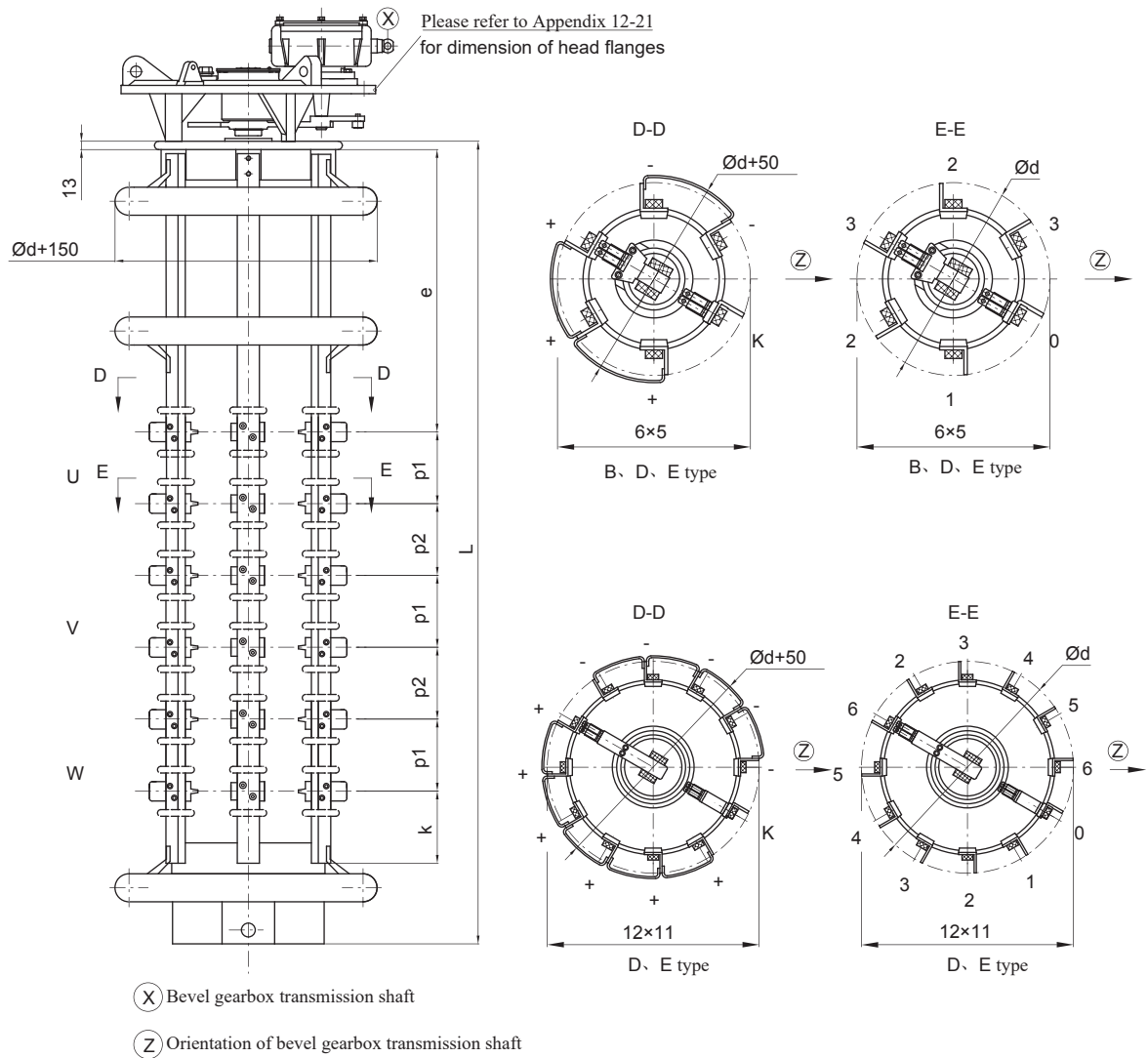

- Note:
- ① Generally type A is applicable to the current of less than 800A
  - ② Connect dimension. Please refer to Appendix 20
  - ③ Regularly Huaming connection "+" and "+", "-" and "-", as shown "D-D", Others connection by customers
  - ④ A、B、D and E type cage outer diameters:  $\Phi 350\text{mm}$ 、 $\Phi 500\text{mm}$ 、 $\Phi 600\text{mm}$  and  $\Phi 750\text{mm}$

Connection	Y				
	e	p1	p2	k	L
Highest Voltage for equipment					
252 kV	980	170	170	155	2200

Unit :mm

## Appendix 9 1000-2000A Reversing regulation, overall dimension

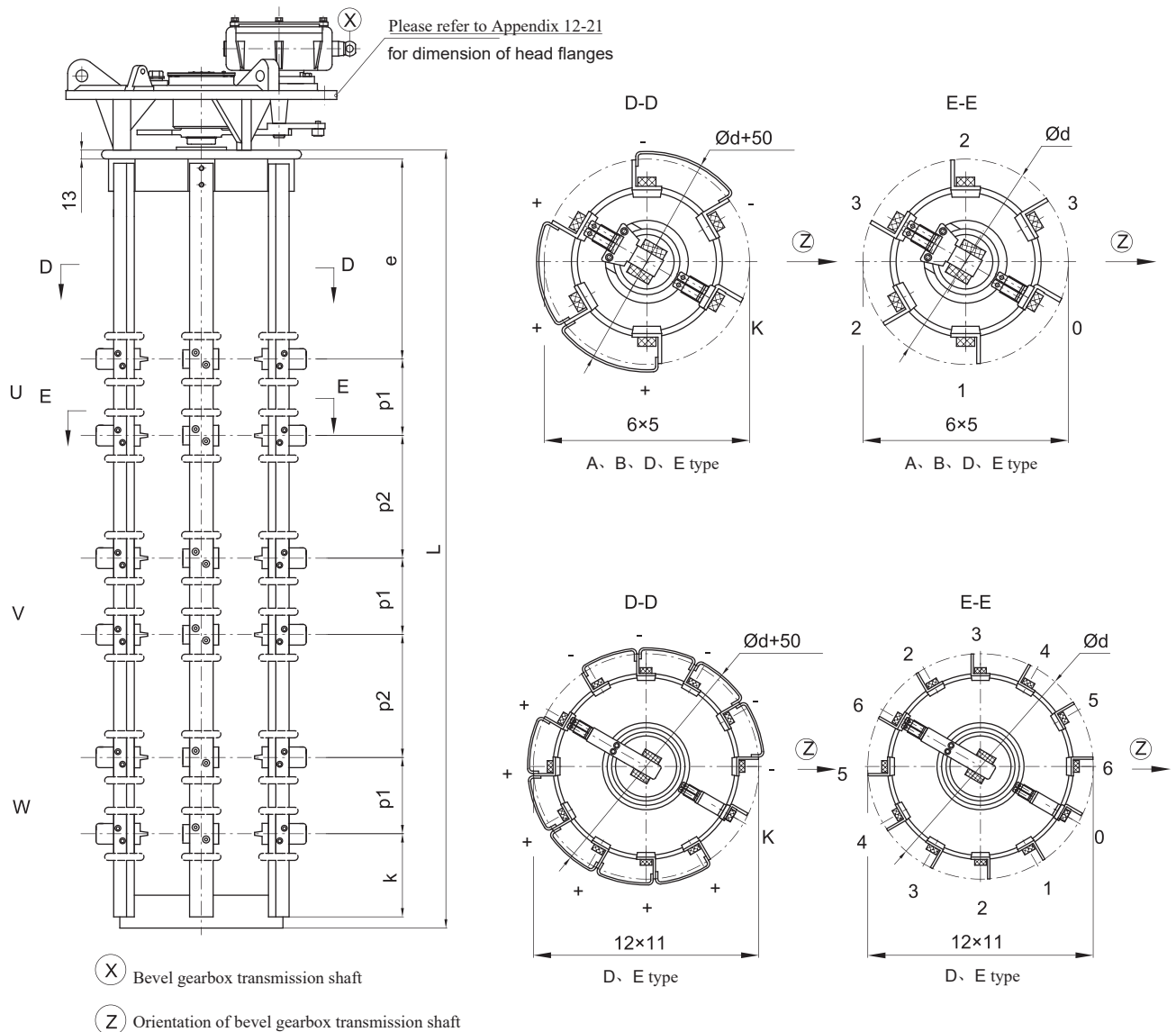

- Note:
- ① Generally type A is applicable to the current of less than 800A
  - ② Connect dimension. Please refer to Appendix 20
  - ③ Regularly Huaming connection "+" and "+", "-" and "-", as shown "D-D", Others connection by customers
  - ④ A, B, D and E type cage outer diameters:  $\Phi 350\text{mm}$ ,  $\Phi 500\text{mm}$ ,  $\Phi 600\text{mm}$  and  $\Phi 750\text{mm}$

Connection	Y					D				
	e	p1	p2	k	L	e	p1	p2	k	L
Highest Voltage for equipment										
12 kV	170	120	120	125	930	200	120	150	125	1020
72.5 kV	340	135	160	150	1250	340	160	280	145	1560
126 kV	470	170	170	155	1510	470	170	410	155	1990

Unit :mm

## Appendix 10 Installation flange for standard tank cover, overall dimension

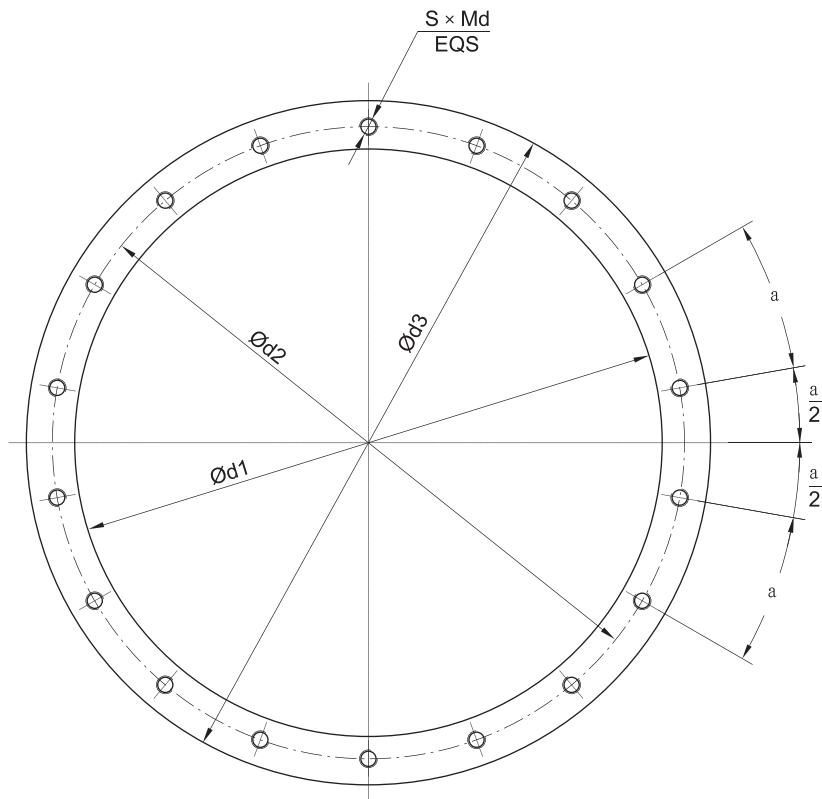
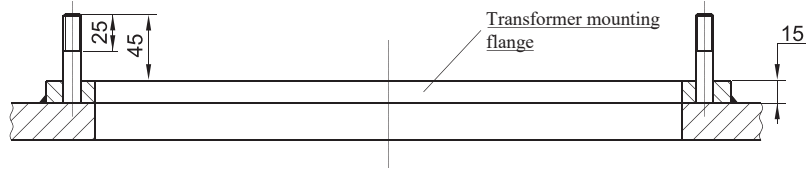

	Diameter d1	Diameter d2	Diameter d3	Bolt S × Md	Angle a
A type	Φ 395	Φ 425	Φ 460	18 × M12	20°
B type	Φ 520	Φ 550	Φ 590	20 × M12	18°
D type	Φ 620	Φ 650	Φ 690	20 × M12	18°
E type	Φ 770	Φ 800	Φ 840	20 × M12	18°

Unit :mm

### Appendix 11 Installation flange for bell type tank cover, overall dimension

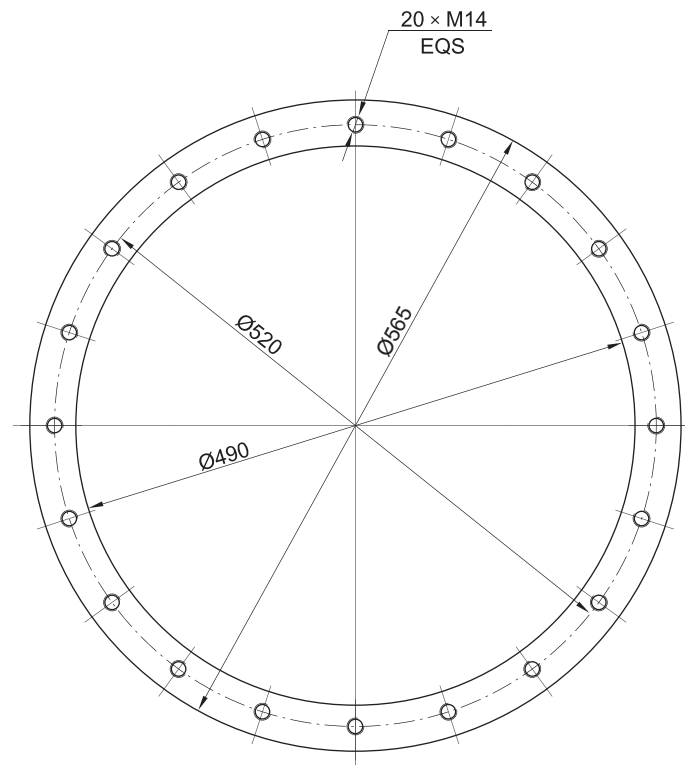
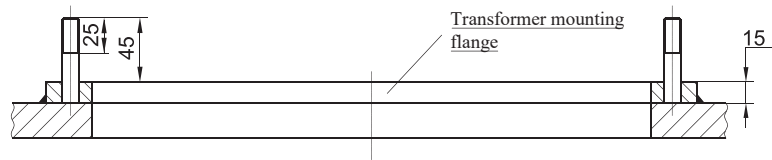

Unit :mm

## Appendix 12 Ground motor drive (manual), Type A for standard tank, head flange dimensions

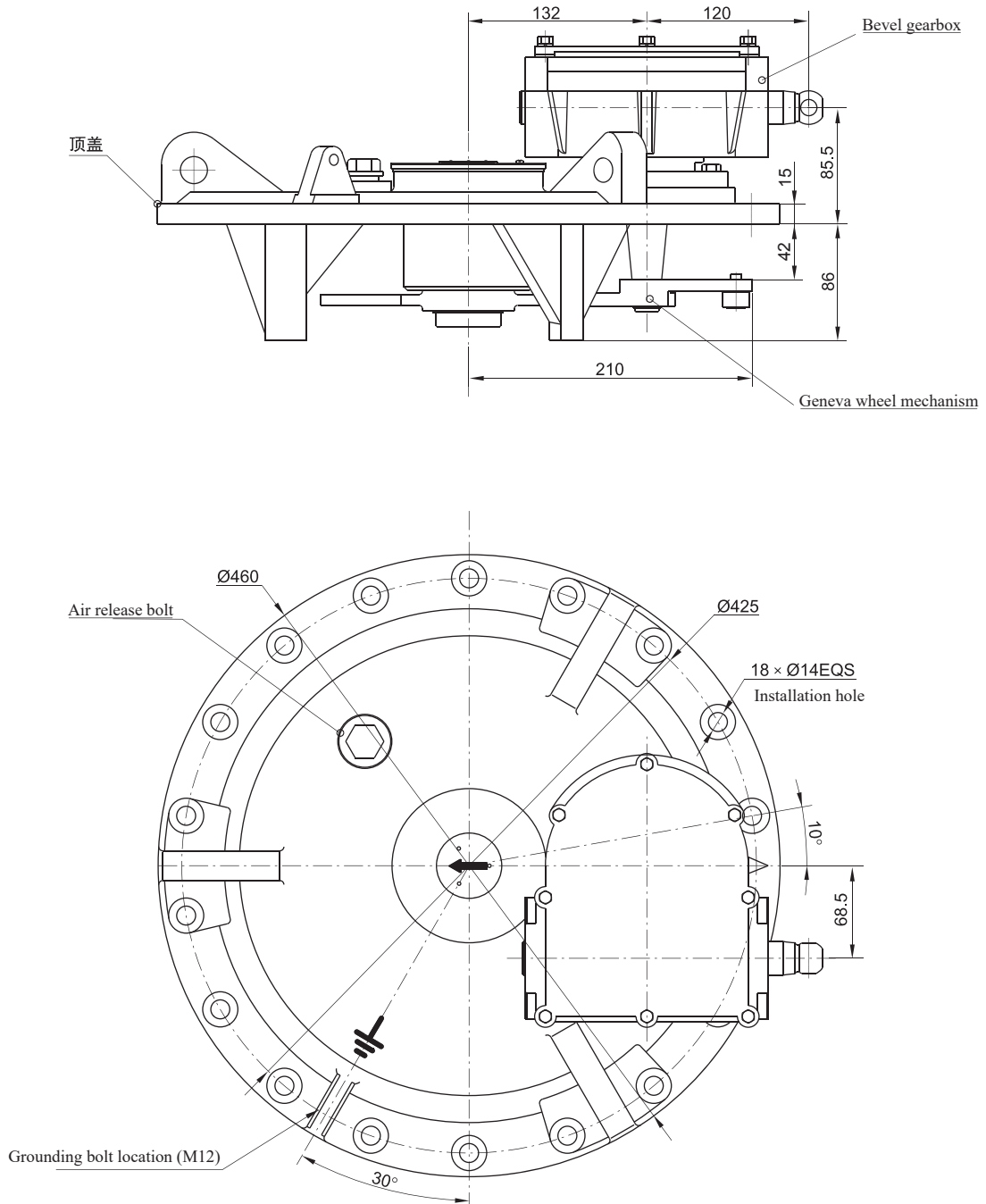

Unit :mm

### Appendix 13 Ground motor drive (manual), type B, D, E for standard tank, head flange dimensions

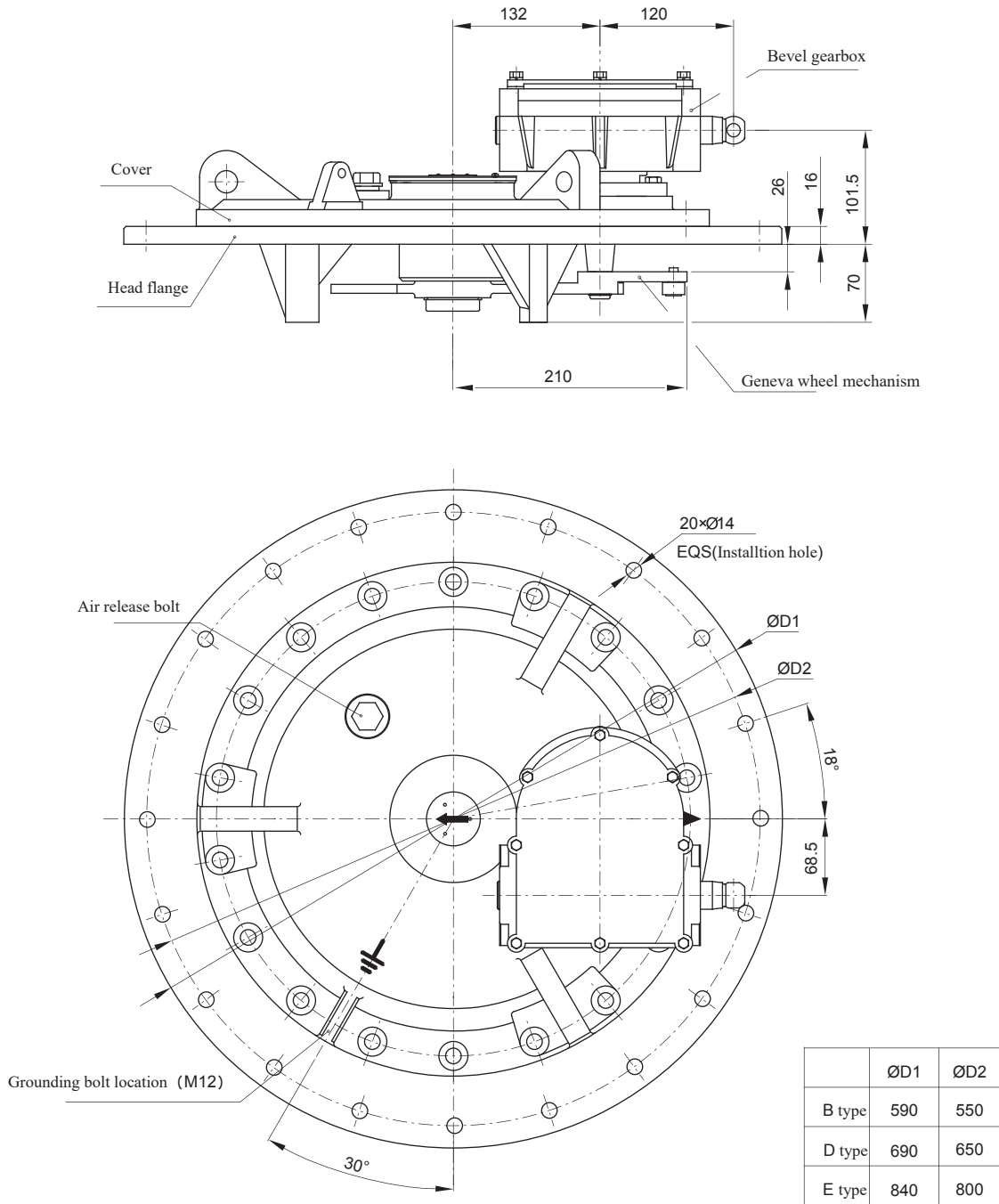

Unit :mm

## Appendix 14 Top cover hand wheel type A for standard tank, head flange dimension

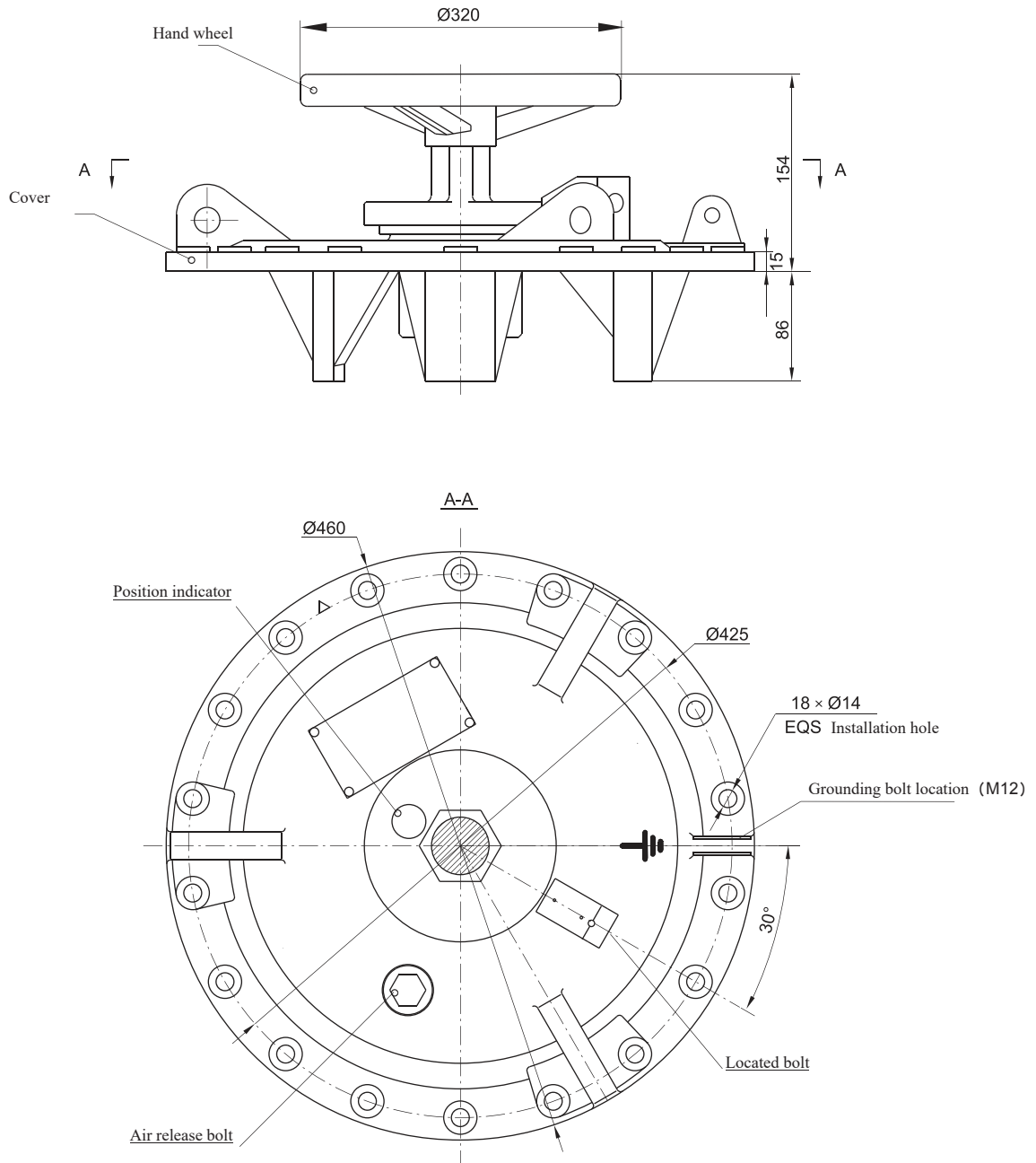

Unit :mm

## Appendix 15 Top cover hand wheel type B, D, E for standard tank, head flange dimension

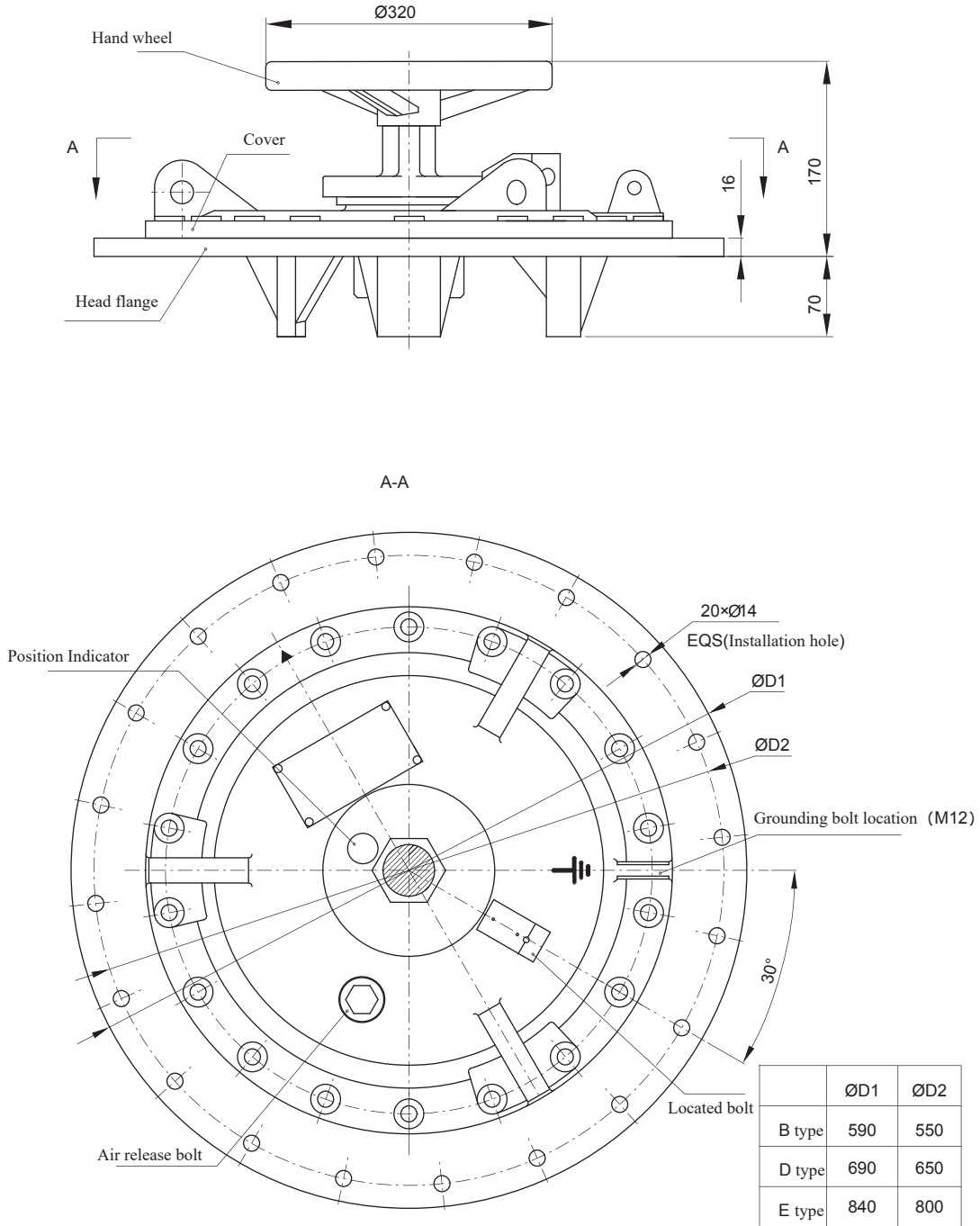

Unit :mm

## Appendix 16 Ground motor drive (manual), Type A for bell type tank, head flange dimensions

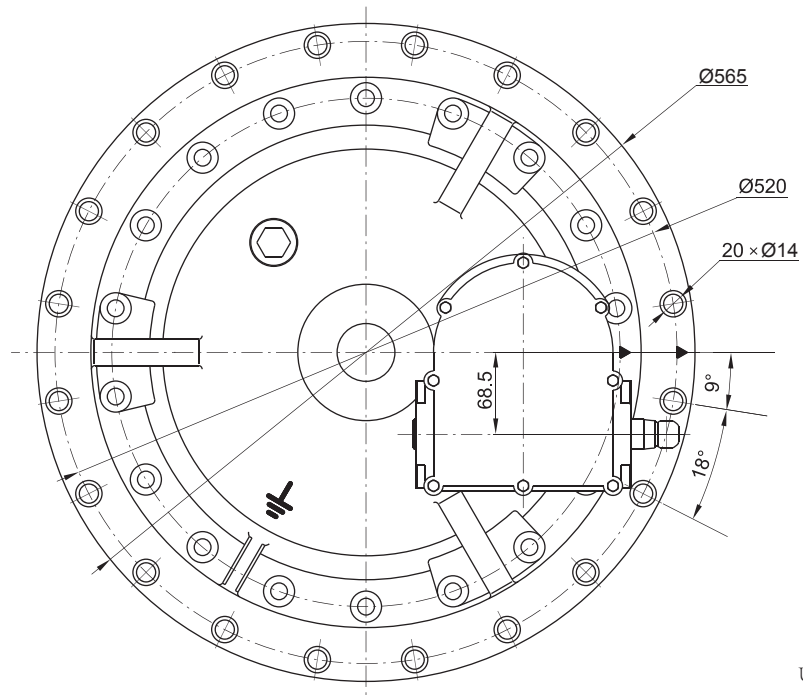
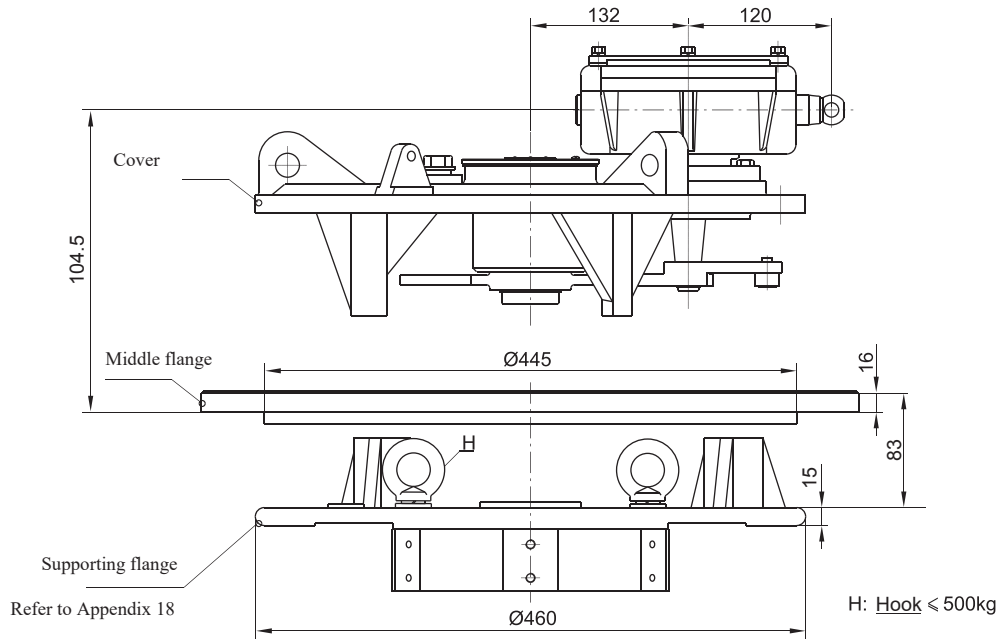

## Appendix 17 Ground motor drive (manual), type B, D for bell type tank, head flange dimensions

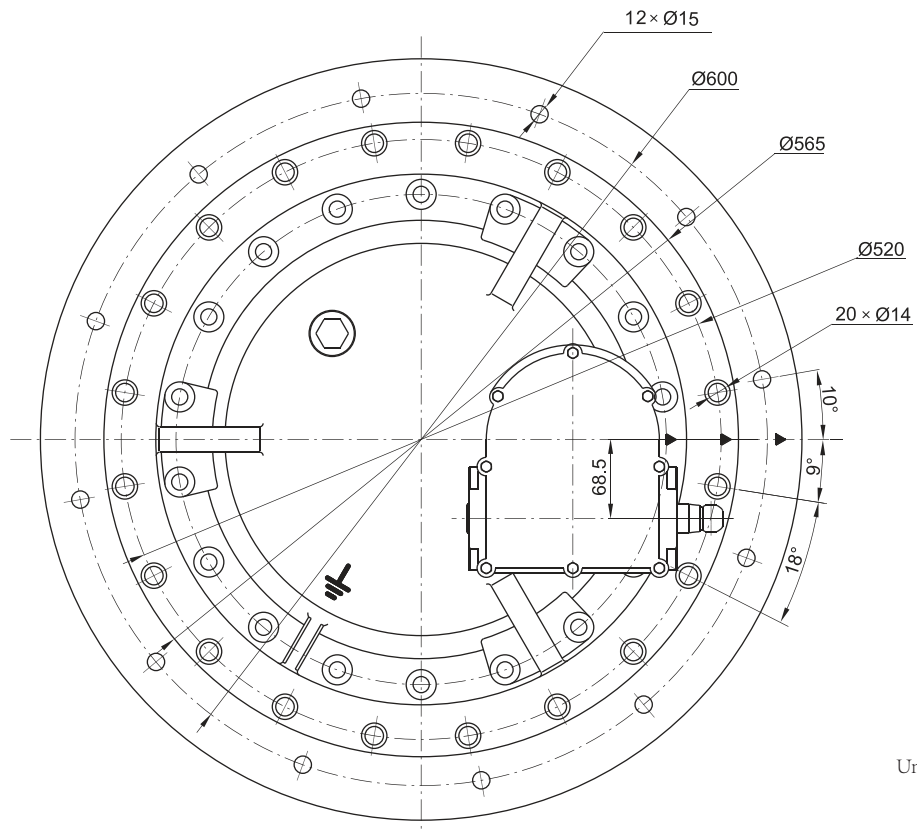
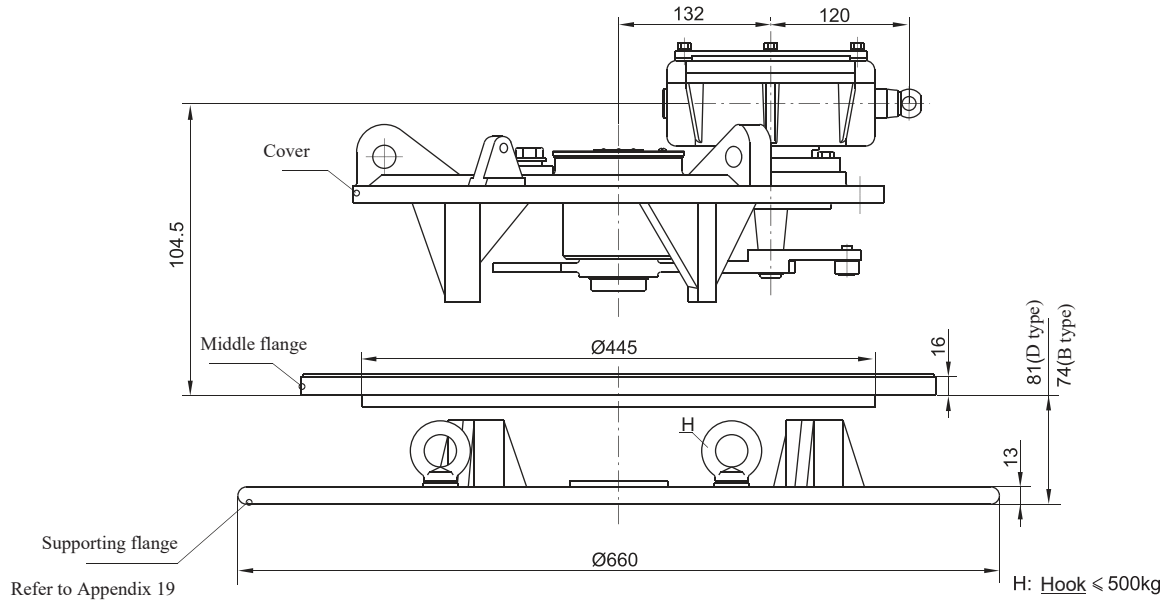

Unit: mm

## Appendix 18 Ground motor drive (manual), type E for bell type tank, head flange dimensions

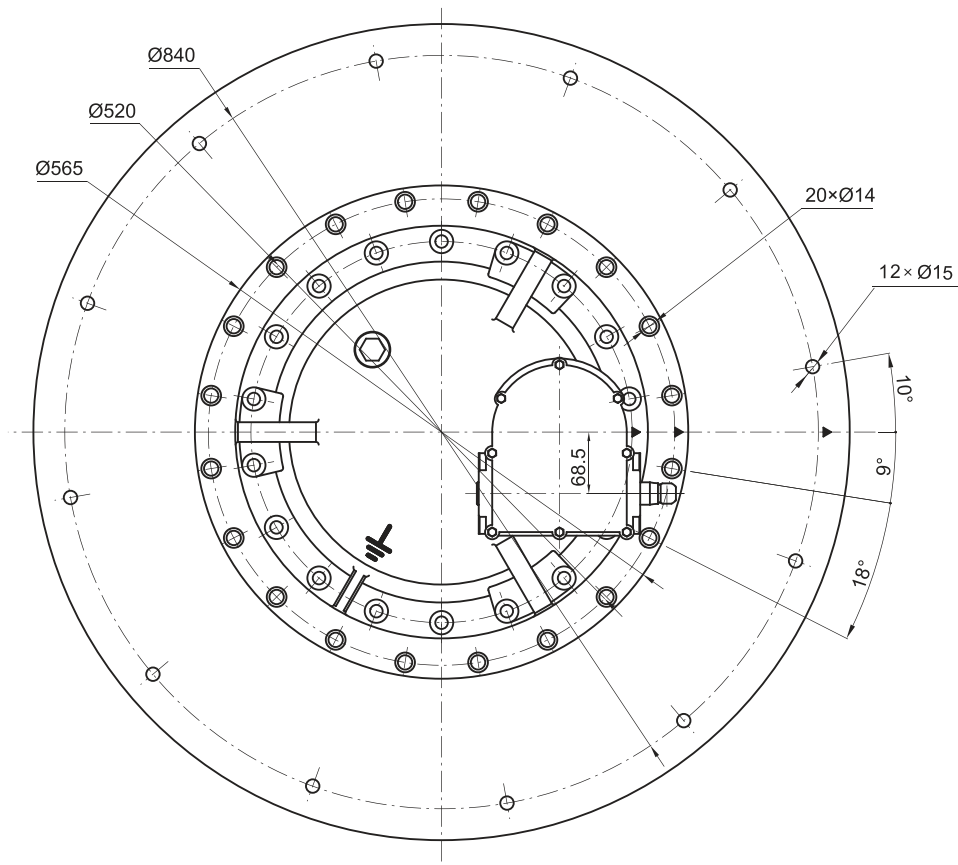
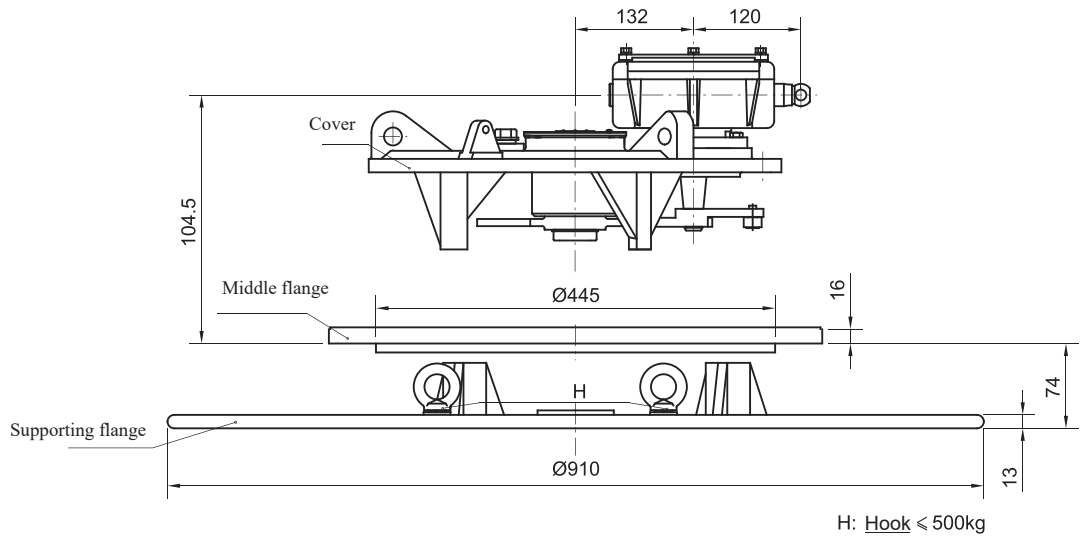

Unit: mm

### Appendix19 Top cover hand wheel type A for bell type tank, head flange dimension

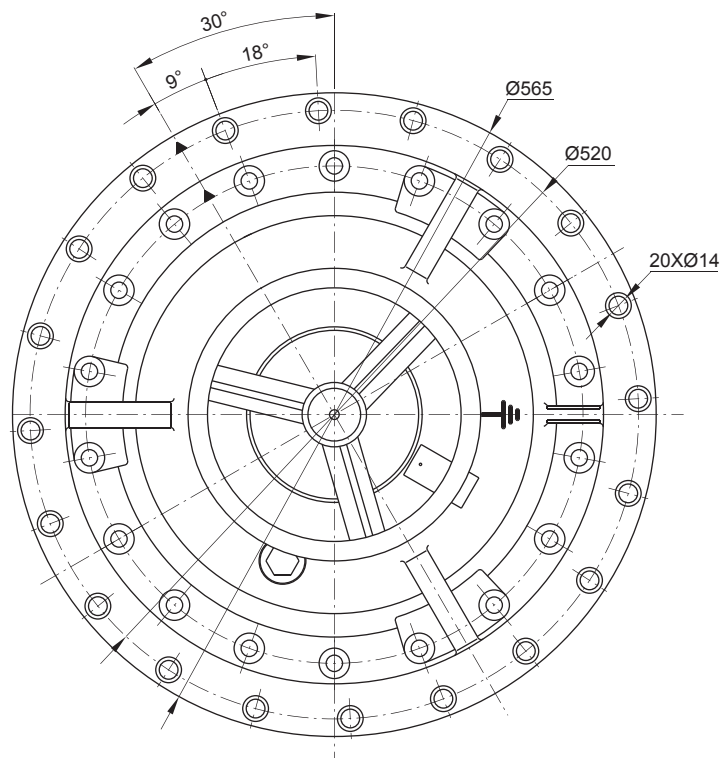
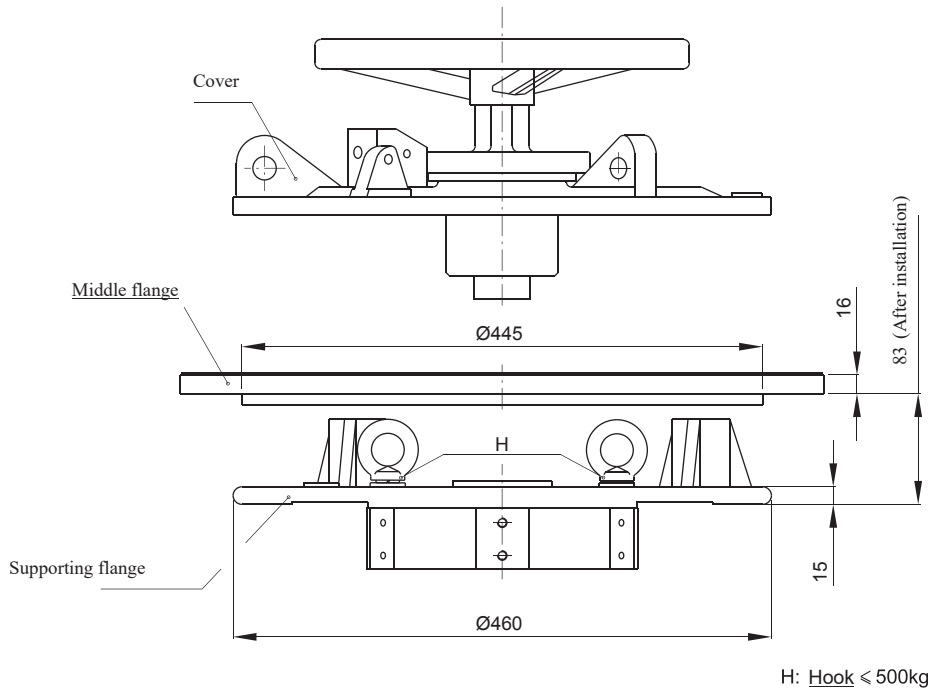

Unit:mm

## Appendix 20 Top cover hand wheel type B, D for bell type tank, head flange dimension

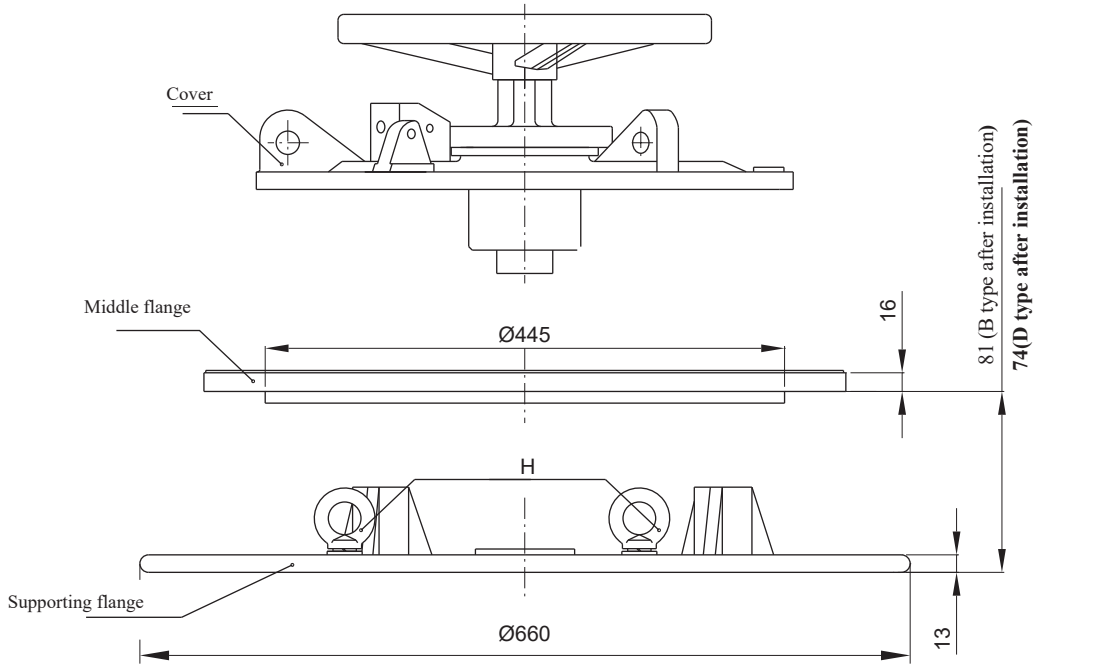

H: Hook <math>\leq 500\text{kg}</math>

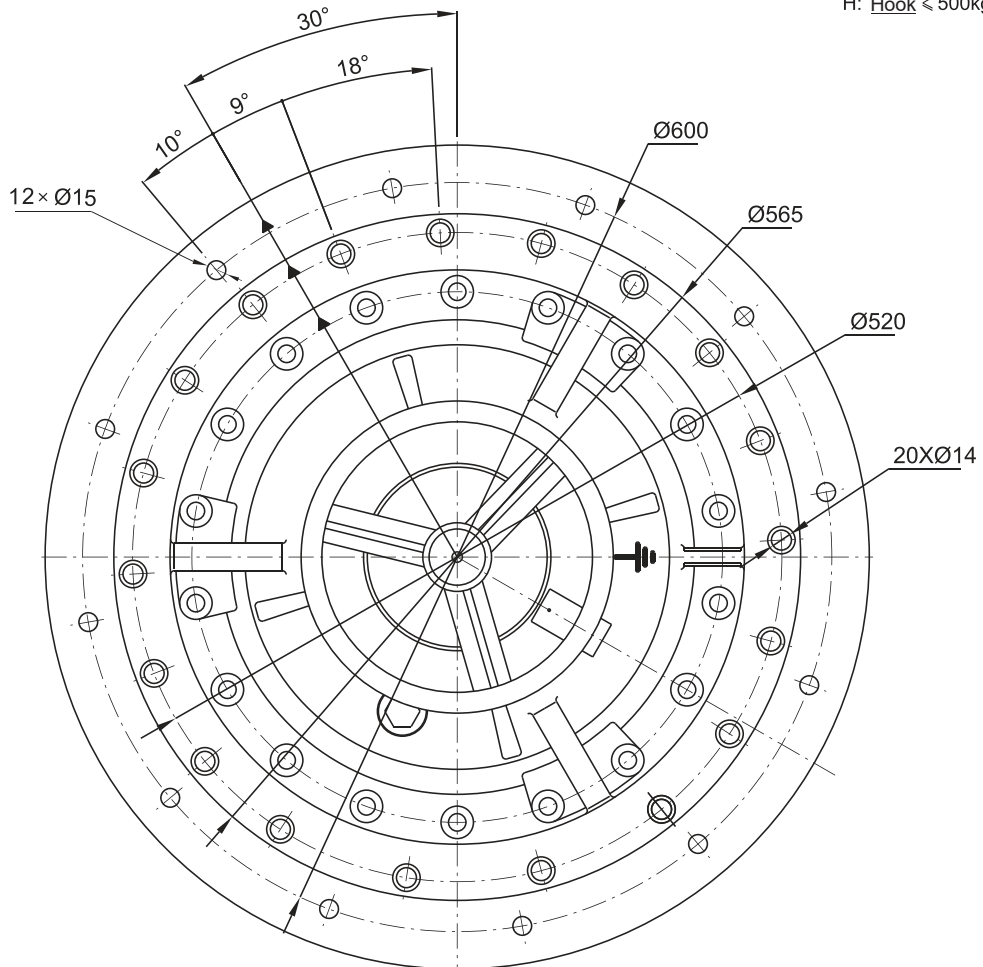

Unit :mm

### Appendix 21 Top cover hand wheel type E for bell type tank, head flange dimension

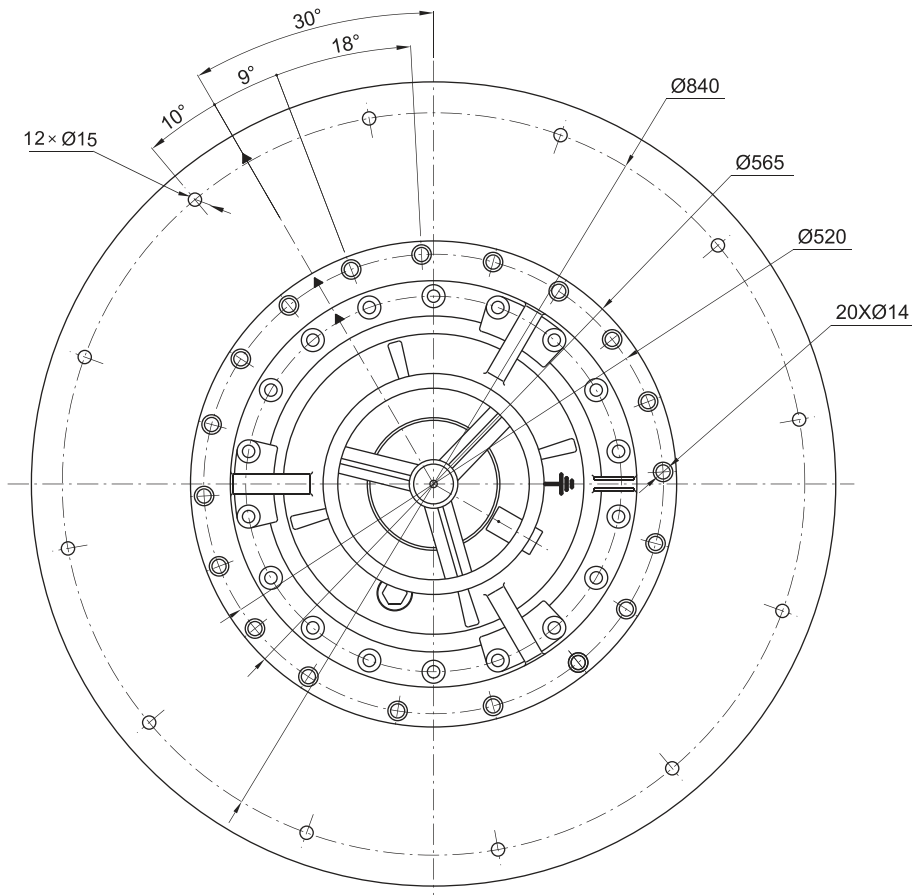
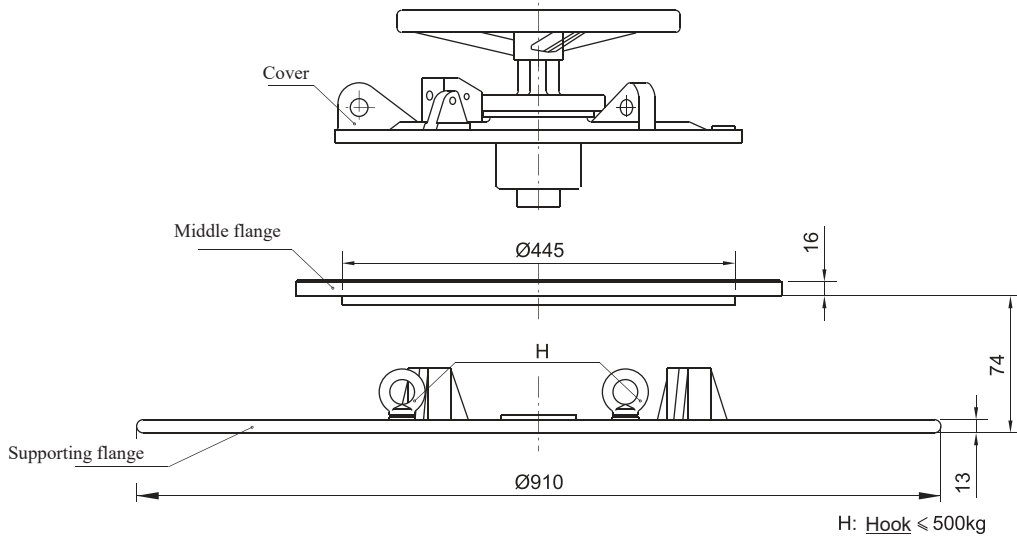

Unit:mm

### Appendix 22 Type A bell type supporting flange, installation drawing

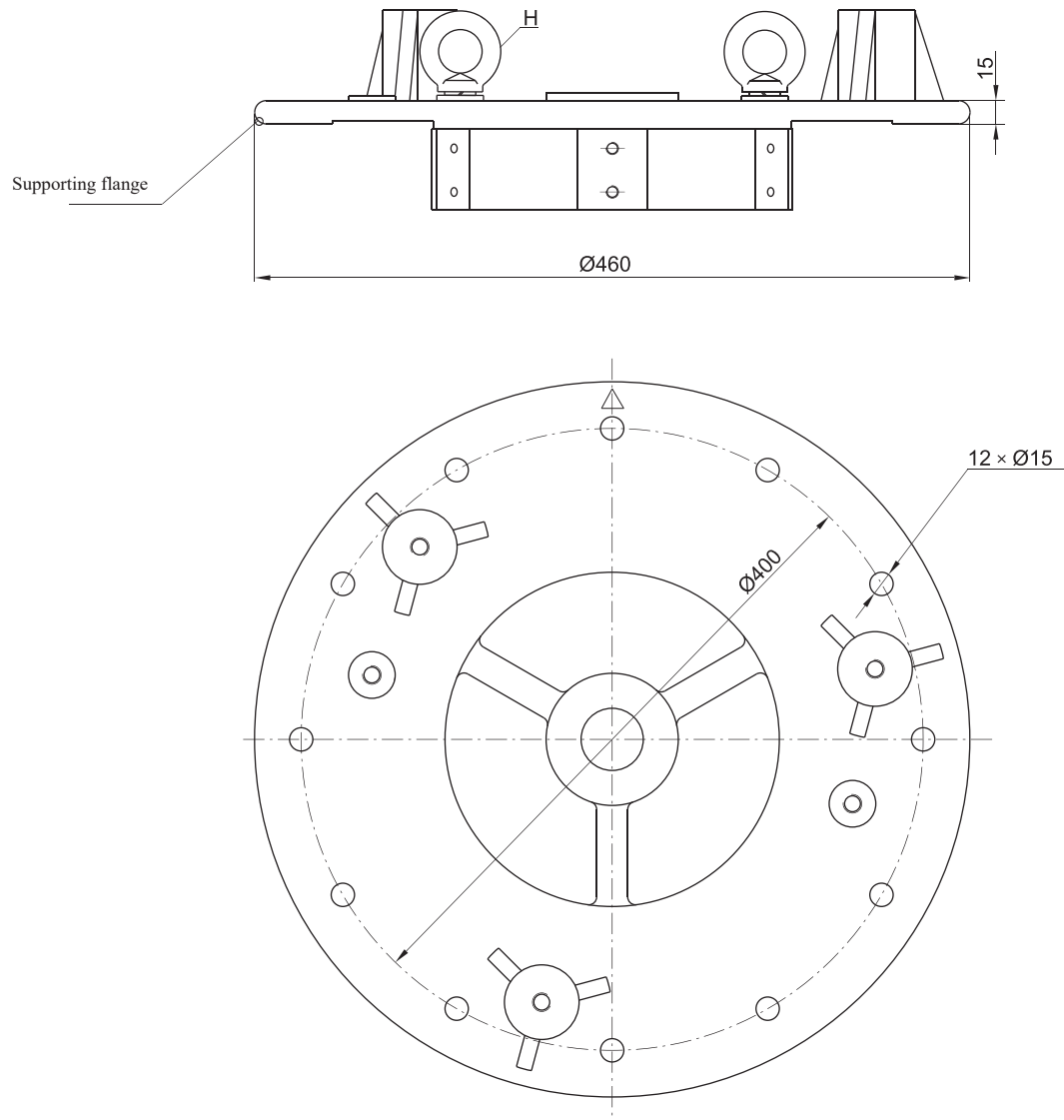

Unit :mm

Appendix 23 Type B, D bell type supporting flange, installation drawing

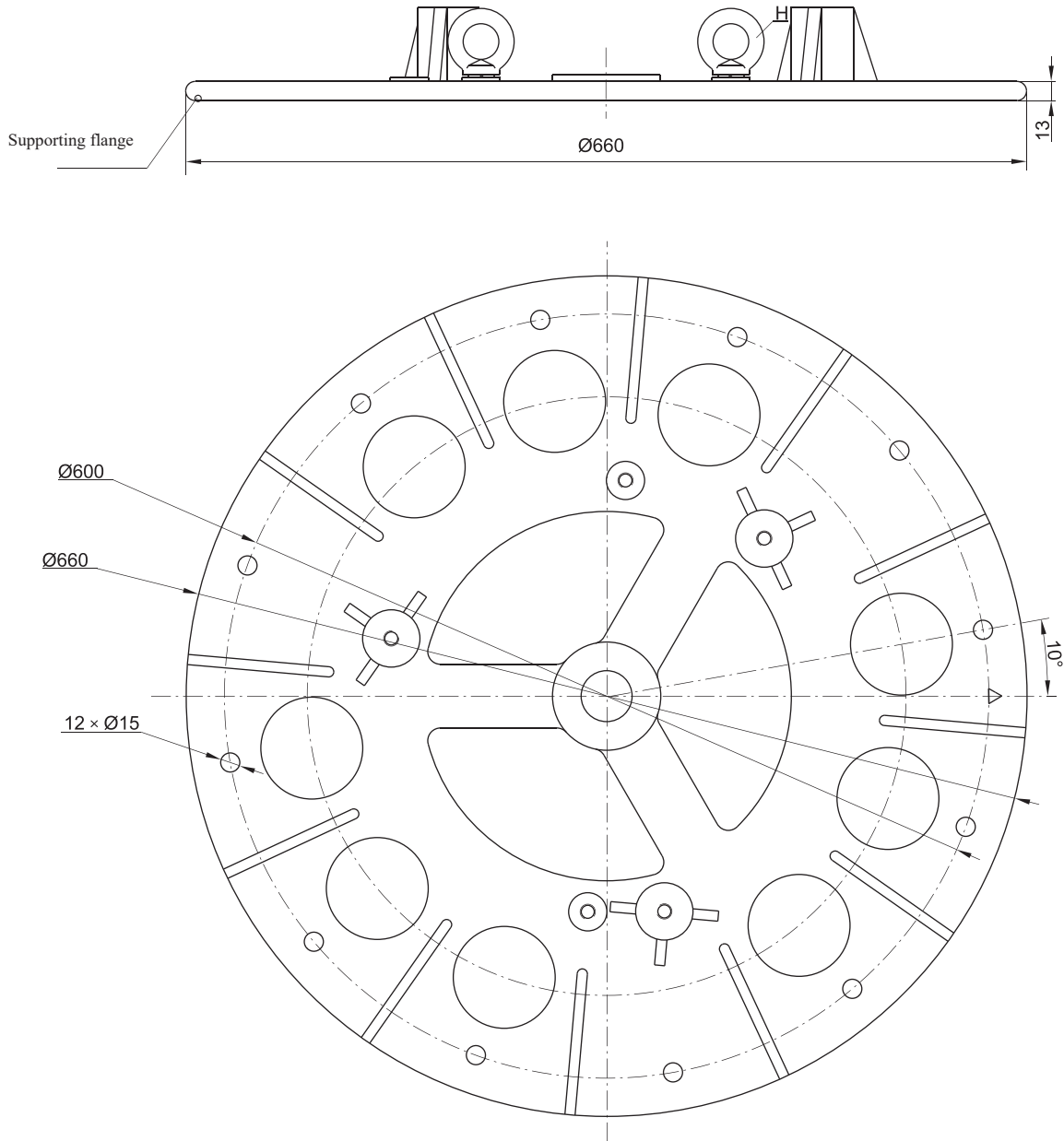

Unit :mm

**Appendix 24 Type E bell type supporting flange, installation drawing**

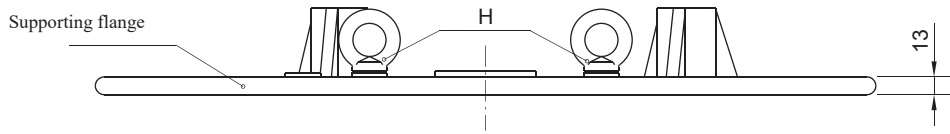

H: Hook  $\leq$  500kg

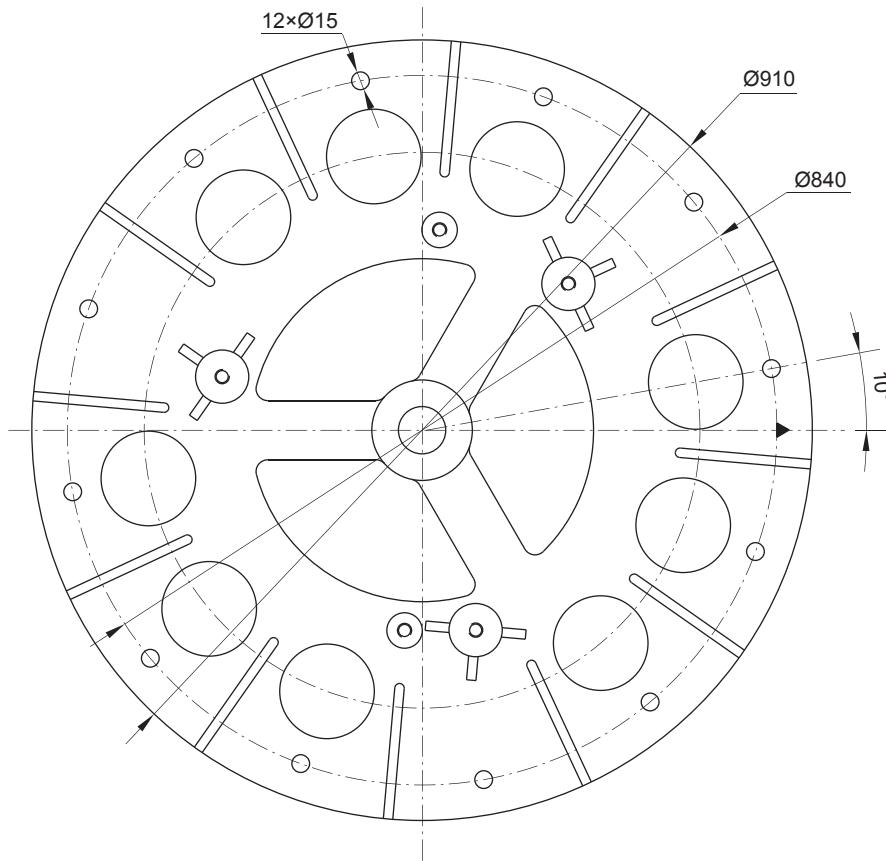

Unit :mm

## Appendix 25 Tap changer terminal, overall dimension

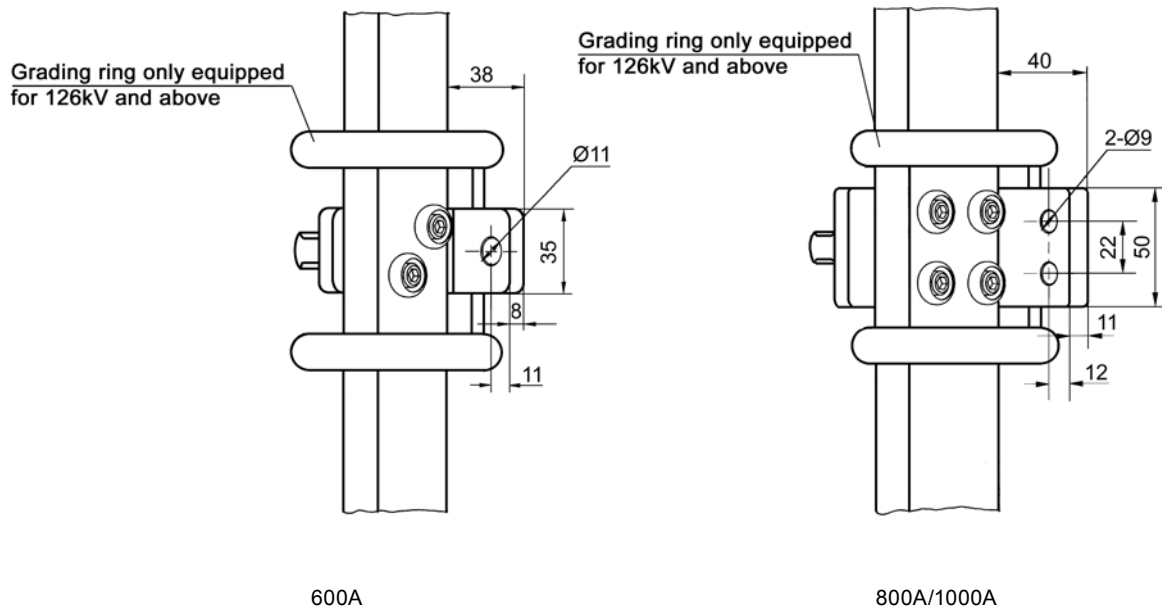

## Appendix 26 Ground motor drive, Tap changer installation drawing

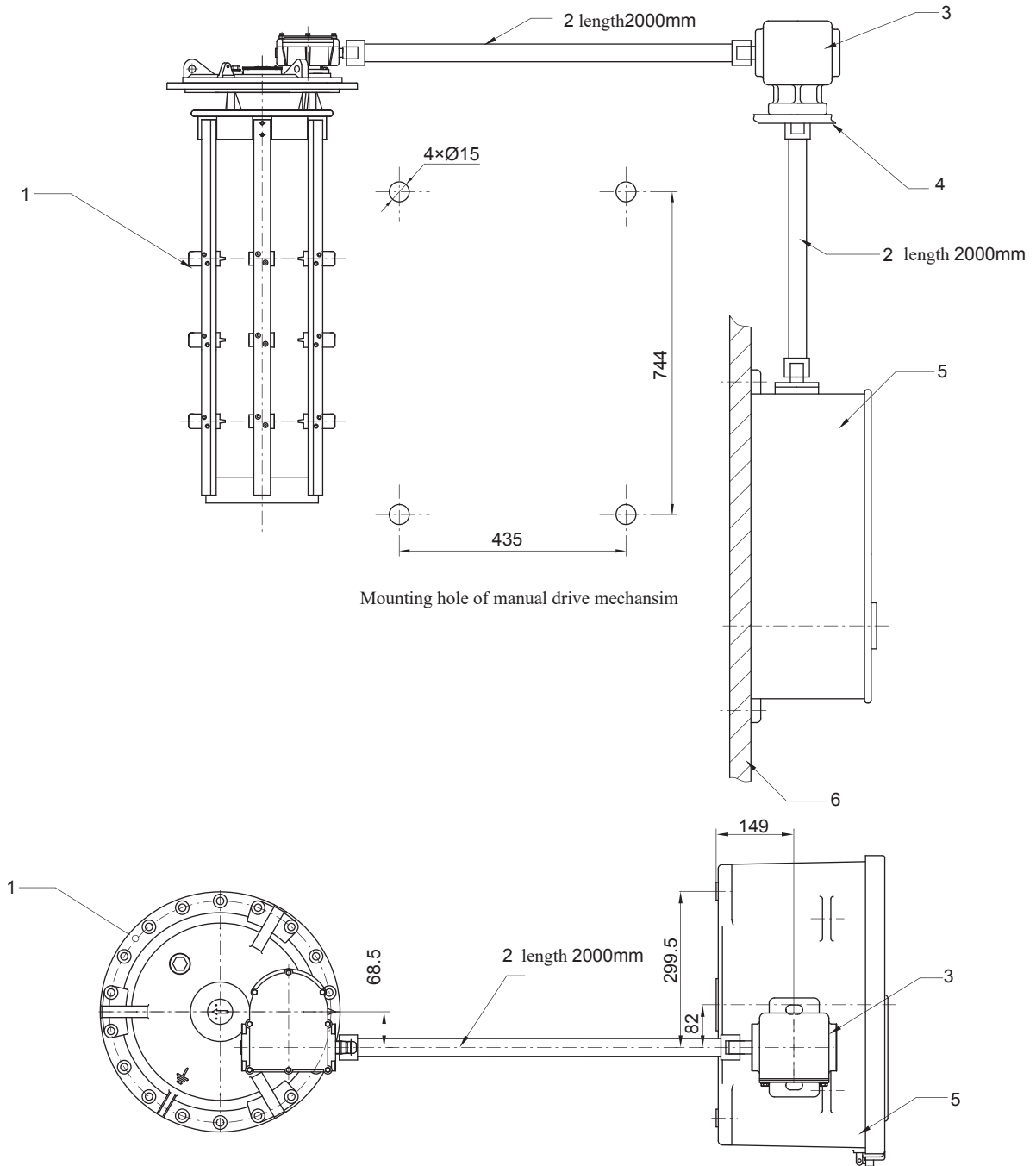

- |   |          |  |  |
|---|----------|--|--|
| 1. Tap changer body                         | 2. Shaft | 3. Bevel gearbox                             | 4. Installation supporting plate (customers) |
| 5. SHM-D MDU (with SHM-K remote controller) |          | 6. Installation supporting plate (customers) |  |

Unit :mm

## Appendix 27 Ground manual drive, Tap changer installation drawing

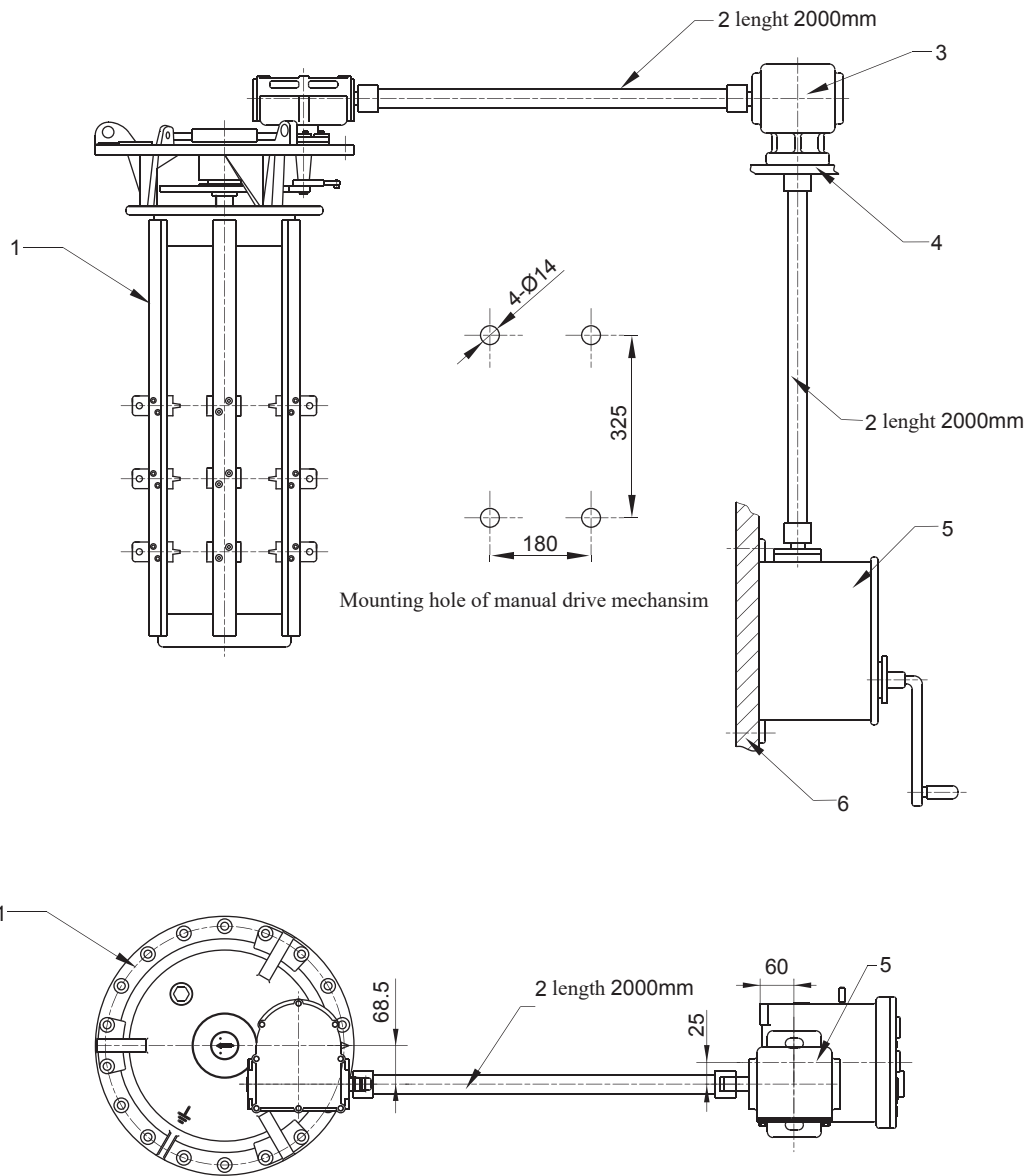

1. Tap changer body 2. Shaft 3. Bevel gearbox 4. Installation supporting plate (customers)  
5. SL driving unit 6. Installation supporting plate (customers)

Unit:mm

## Appendix 28 Bevel gear, over dimensions

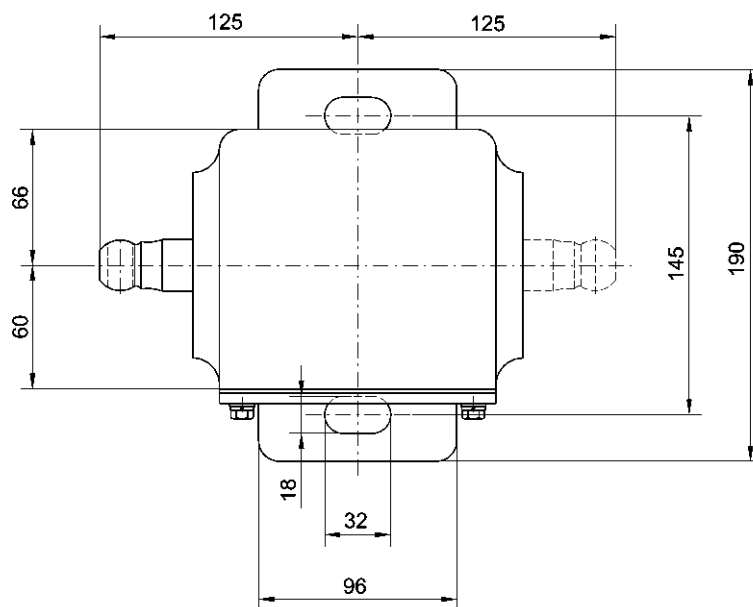
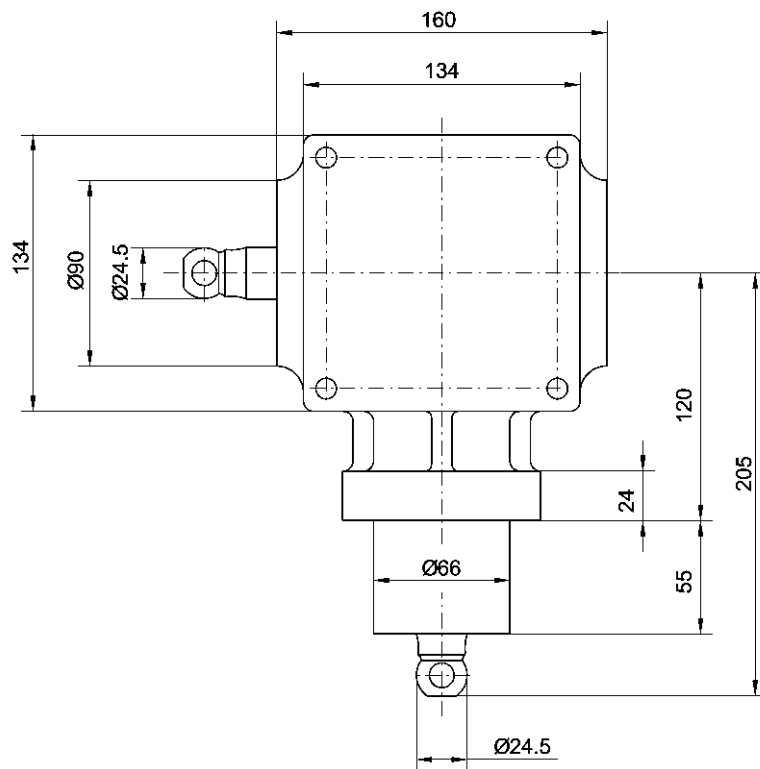

Unit: mm

## Appendix 29 Side-manual operation, overall dimension

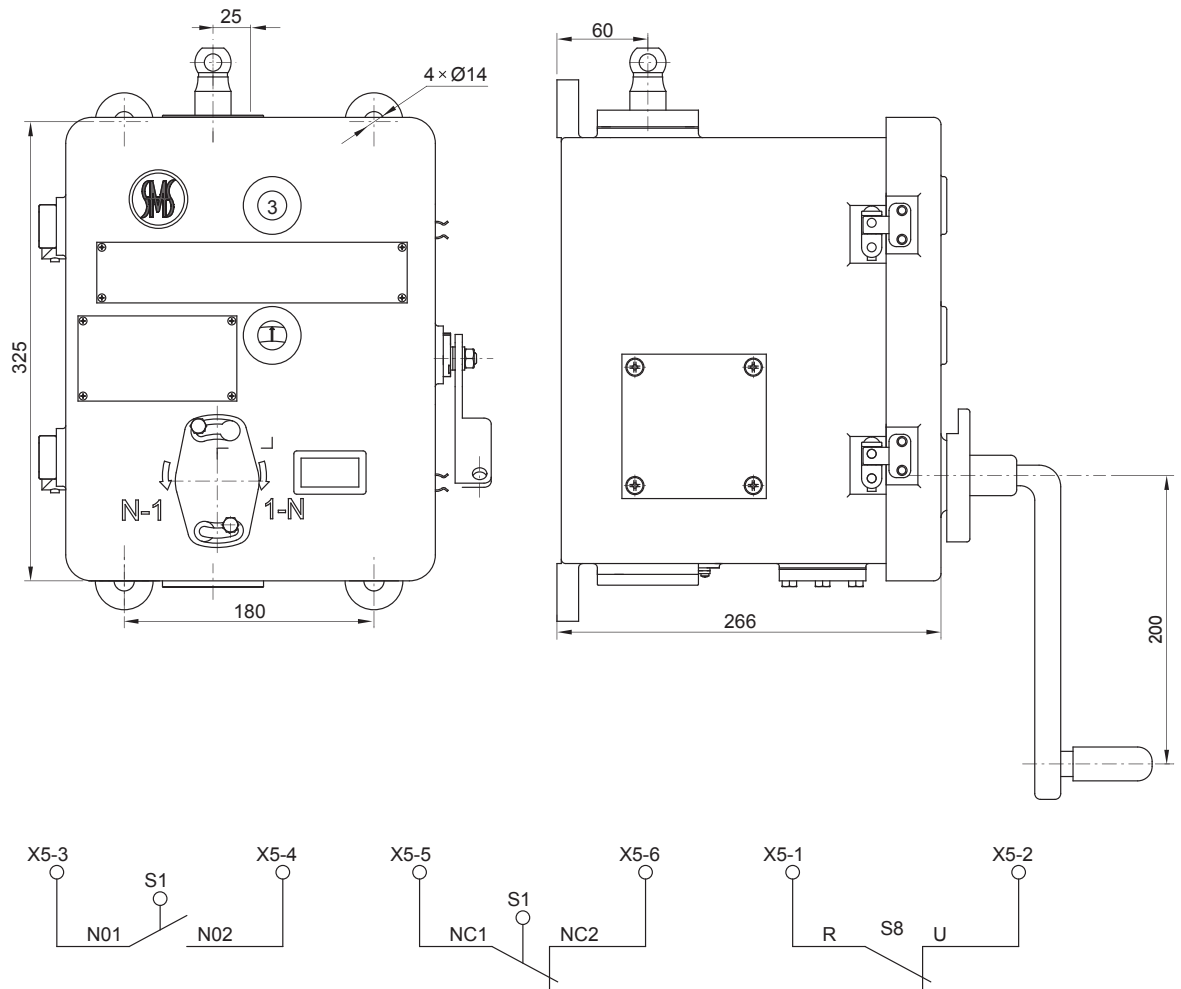

S1-NO1, S1-NO2 are the operation in progress signals. S1-NC1, S1-NC2 are the operation complete signals. S8-R, S8-U are drawn from the manual drive mechanism to terminal X5-1, X5-2. If hand crank is inserted for manual operation, then the X5-1, X5-2 are disconnected so that the contacts will open. If hand crank is removed, then the X5-1, X5-2 are connected. The signals are used for interlock between the tap changer and the transformer circuit breaker.

Unit:mm

## Appendix 30 SHM-D Overall Dimension

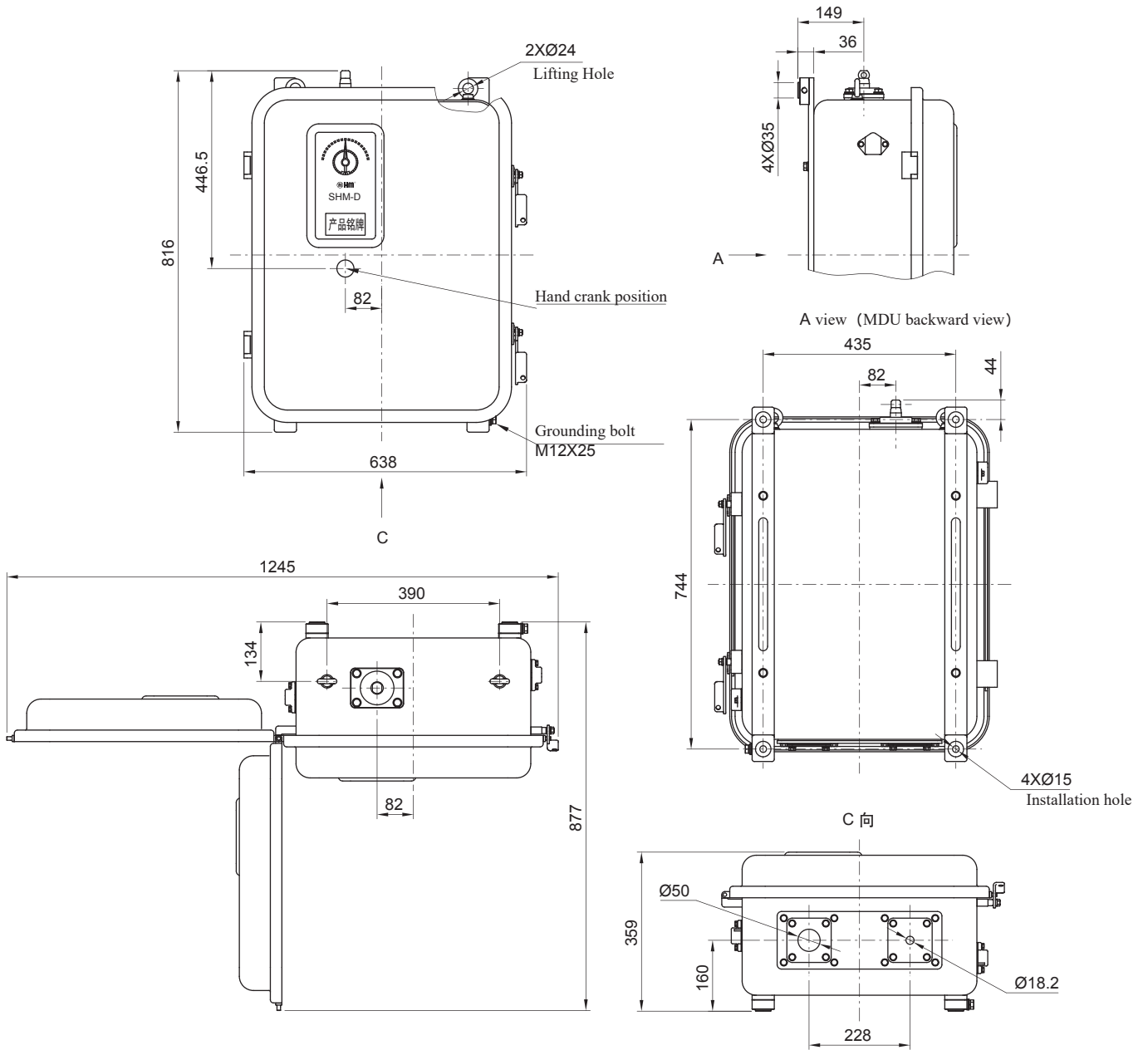

Unit ;mm

## Appendix 31 SHM-K Remote controller Installation

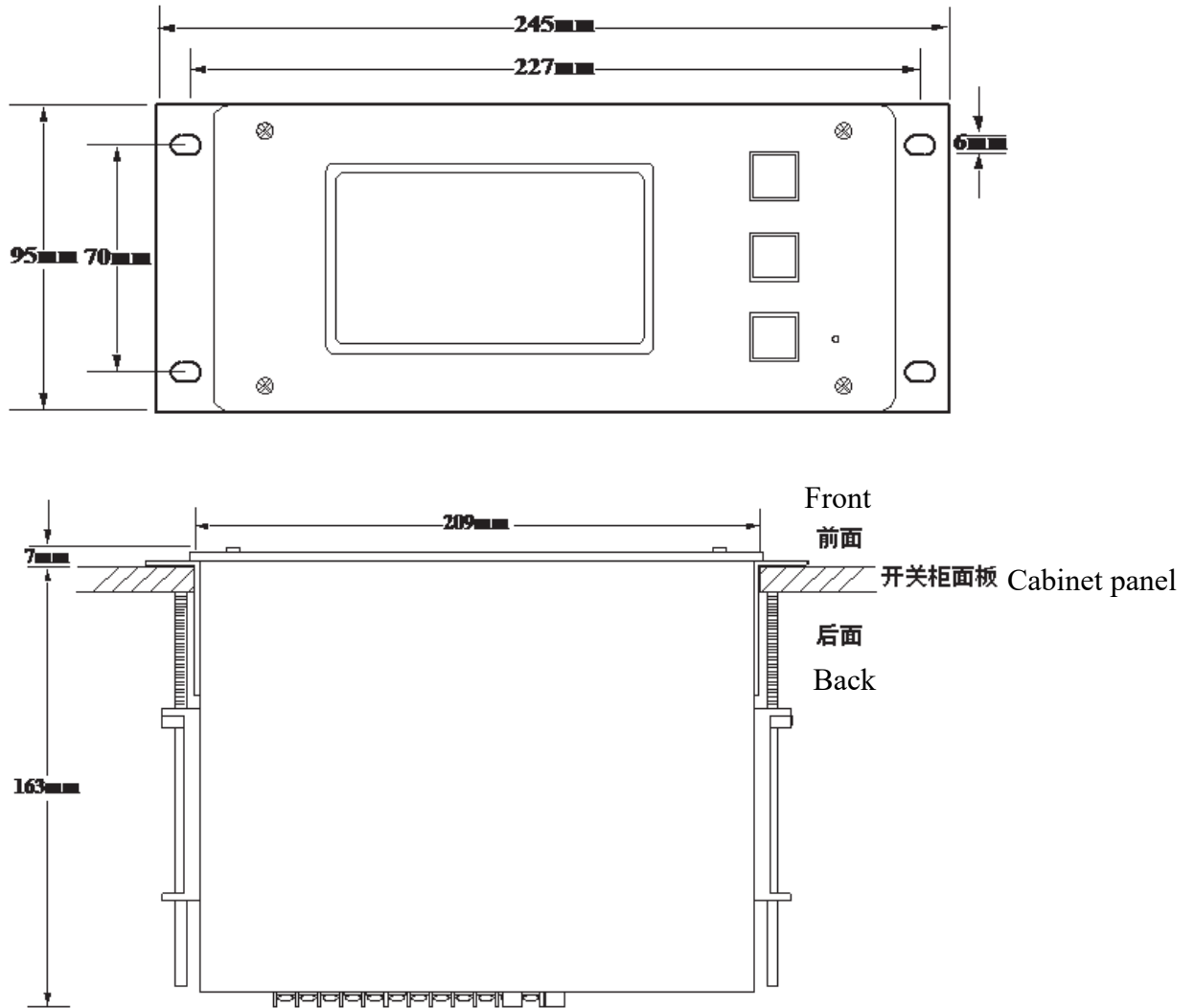

**Note:**

The installation method can be fixed and installed with the front screw, or it can be installed with the pin lock on both sides as shown in the figure above. Opening size: 210mm×96mm (length × width)

**Shanghai Huaming Power Equipment Co., Ltd.**

Address: No 977 Tong Pu Road, Shanghai 200333, P.R.China

Tel: +86 21 5270 3965 (direct)

+86 21 5270 8966 Ext. 8688 / 8123 / 8698 / 8158 / 8110 / 8658

Fax: +86 21 5270 2715

Web: [www.huaming.com](http://www.huaming.com) E-mail: [export@huaming.com](mailto:export@huaming.com)