



SHM-D Digital Control Motor Drive Unit Operation instruction

HM 0.460.1381-04.07/2016



Shanghai Huaming Power Equipment Co., Ltd.

Preface

1. This operation instruction contains all information required for the installation and operation of SHM-D motor drive unit. Please read it carefully before using it.
2. The maintenance of this motor drive unit shall be taken by trained professionals.
3. Huaming is entitled to edit this operation instruction according to future technical improvement.
4. In case users' requirement is beyond the standard technical data or applied in special cases, please contact us. We will recommend personalized solution.

Contents

1. Safety.....	1
1.1 Safety marks.....	1
1.2 Specified application.....	1
2. General.....	2
3. Features.....	3
4. Function and operation condition.....	4
4.1 Function.....	4
4.2 Operation condition.....	4
5. Technical data.....	5
6. Installation and operation.....	6
6.1 Installation on transformer tank.....	6
6.2 Connection between MDU and tap changer.....	7
6.3 Adjustment of operation circle.....	8
6.4 Operation.....	9
6.5 Transportation.....	12
6.6 Maintenance.....	12
7. Appendix.....	12
Appendix 1 SHM-D overall dimensions.....	13
Appendix 2 SHM-DL overall dimensions.....	14
Appendix 3 Internal components layout.....	15
Appendix 4 Local control panel arrangement.....	16
Appendix 5 Electrical diagram.....	17
Appendix 6 SHM-K controller overall dimension.....	18

1. Safety

1.1 Safety mark

1.1.1 All personnel involved in installation, operation and maintenance of tap changer and motor drive unit shall be qualified professionals while obeys ruled defined by this operation instruction.

1.1.2 Violation may lead harm to users, malfunction of motor drive unit or damage to other assets.

1.1.3 Three types of marks are applied to emphasize different kind important information.



Warning

This information stands for particular damage to human life. Ignoring this can lead to serious or lethal damage.



Attention

This stands for risks of damaging this device and other assets. It may cause potential damage to human life.



Note

It stands for other important things that requires your attention.

1.2 Specified application



Attention

This MDU can only applied to the specified OLTC in the nameplate.

The installation, electrical connection and trial operation can only be carried out by qualified professional.

Users shall operate this MDU according to the instructions.

2. General:

SHM-D motor drive unit is the new intelligent digital control drive mechanism. It can be applied to the whole range of HM tap changers.

In past decades, the motor drive unit is the conventional system of electric-magnetic contactors with various mechanical cam switches. Its structure is clumsy with low reliability. According to the statistics, 75% of tap changer accident are found on MDU. Its mechanical components may easily go loose or corroded under challenging environment.

Based on cutting edge technologies from automation, astronautic and bullet train industry, Huaming designed the new MDU SHM-D. It can decrease the failure rate to 0.01%. By increasing on-line monitor functions, the tap changer operation will be more stable in the future.



Fig1 MDU SHM-D arrangement

3. Features.

3.1 All moveable components are run precisely by step motor, their operation accuracy can reach 100%

3.2 Instead of copper wire, the connection between motor and controller is by optical fiber cable.

3.3 Non-contact type high-precision sensor replaces traditional signal producer. It has excellent resistance disturbance capability and ensure excellent performance under various harsh environment.

3.4 *Various on-line monitor devices are equipped. This can ensure the tap changer and transformer will be locked and given alarm for abnormal operation. It can even indicate the oil temperature and alarm.

3.5 *It can detect the vacuum decrease in the vacuum interrupter and alarm.

3.6 *It can sense the wear out of arcing alloy contact and give signal when its expectancy finishes.

3.7 Its cabinet box is made of high quality aluminium alloy plate material via compressing and stretching. Its protection degree can reach IP66.

3.8 Double-sealed protection are applied on its cabinet

3.9 All electrical and mechanical components are with capability of disturbance resistance .

3.10 It can detect the gas inside tap changer or transformer oil and operate the on-line filter automatically.

3.11 It can regulate the voltage automatically, saving you the cost of AVR.

3.12 It can realize parallel operation without extra controller

3.13 Modular design.

3.14 High precision position transmitting system

3.15 It has a variety of communication interface and communication protocol, and provides more choices for smart grid applications.

*** Marked item should be applied in cooperative with the user's request.**

4. Function and Operation condition

4.1 Function

- 4.1.1 Manual operation and motor operation
- 4.1.2 Remote control or local control
- 4.1.3 Step-by-step operation, overrunning at special request.
- 4.1.4 Local position indication and remote position indication
- 4.1.5 Tap position display
- 4.1.6 Electrical and mechanical limit switch
- 4.1.7 Local operation button
- 4.1.8 Operation counter
- 4.1.9 Overload protection
- 4.1.10 Parallel control
- 4.1.11 Restart device
- 4.1.12 Protection against overrun
- 4.1.13 Standard optical fiber transmitting interface
- 4.1.14 Over-current blocking signal input
- 4.1.15 BCD signal output
- 4.1.16 Contact signal output
- 4.1.17 4-20mA or 1-5V analog output signal.
- 4.1.18 Operation status signal output.
- 4.1.19 Motor drive unit accident detection and locking device

4.2 Operation conditions

- 4.2.1 Ambient temperature -25-60°C (Special designed low-temperature type can withstand -60°C)
- 4.2.2 Installation vertical inclination is no more than 2%
- 4.2.3 No severe sand dust, explosives or corrosive gas is allowed for the site.

Note



the ambient temperature is beyond the regulated range in 4.2.1, please specify it in the technical specification. We will meet the special requirement by personalized design.

5. Technical data

This technical data is only applied to the standard design. It may vary according to different request in technical specification. Huaming reserves the right to revise the data in this table.

table1

Item		SHM-D	SHM-DL
Step motor	Rated voltage V	200-240V/AC	
	Rated current A	6	
	Frequency Hz	50, 60	
Revolution torque on output shaft N.m		35	
Revolutions of drive shaft each step		33	
Revolutions of hand crank each step		33	
Automatic operation time of each step (S)		Approx. 5	
Maximum number of operation position		107	
Insulation grade (kV/1min,50Hz)		2	
Weight (kg)		80	110
Protection grade		IP66	
Controller	Type	SHM-K	
	Rated voltage	85-265V AC/DC	
	Frequency Hz	50, 60	

Table 2 Function

Local control panel	Basic function	Position indication, regulation	
		Step motor, Position measuring sensor, optical fiber communication	
		Mechanical, electrical and electronic protection	
		Position output	One set of BCD signal One 4-20mA, 1-5V output (or two sets of 4-20mA) RS-485 MODBUS protocol
		Operation status	Regulation signal (rise or lower) Max. operation position, Min. operation position, Incomplete signal, on-line oil filter control, hand crank operation signal, remote/ local control
		Manual operation at controller	Optic electronic isolation
		Temperature control	Available for severe cold temperature.
	Interlocking	Remote or on-line monitor signal	
	Optional	Other signal output	Contact signal output Resistor signal output 2 sets of BCD signal output Other communication protocol besides Modbus
		Humidity adjustment	For area of high humidity
Remote control panel	Basic function	Remote position control	Indication and display
		Digital communication	Method: TCP/IP network, UART Protocol: Modbus/CDT/IEC101/IEC104/DNP3.0/1801
		Position output	BCD signal
		Operation record	Time, position, for 800 at most
		Local mode operation situation	Display all local panel operation status. Max. Min. position Working status local communication status, etc.
	Optional	Automatic regulation	
		Parallel operation	2 to 12 units
	Other position output	Contact signal output Resistor signal output Two of BCD signal output 4-20 mA signal output.	

In case you have extra requirement for resistor type or contact signal output, please select the big cabinet MDU SHM-DL

6. Installation and operation

6.1 MDU installation on transformer tank

6.1.1 The mounting feet thickness is 10mm, its installation hole is 4x15mm; for its dimensions, please refer to appendix 1.

Users shall prepare four M12 bolts and gaskets accordingly. The length of bolts depend on support's thickness.



Warning

Ensure the flatness of the installation plane, so four mounting feet will touch the plates at same time.

To avoid the unevenness, please adjust the gasket to ensure the gap is within 1mm



Warning

The OLTC No. on the MDU cabinet nameplate shall be accordance with OLTC No. on tap changer's head cover.



Note

If the transformer will generate severe mechanical vibration during operation, please adopt shock absorption.

6.1.2 The earthing devise locates at right foot as displayed in appendix 1. This bolt shall be M12x25. Users can relocate it as required.



Note

All electrical components and earthing part shall be connected to the cabinet equipotential bonding; no extra earthing is required inside the cabinet



Warning

Users are forbidden from connecting other device's earthing with the MDU's.

6.2 Connection between motor drive unit and tap changer

6.2.1 Along with the tap changer, there are two shafts, four couplings (two for each) and four pieces of pins

6.2.2 The Max. drive shaft length is 2000mm, The user can modify its length according to the actual distance with MDU output shaft and lowering ending of bevel gear box as shown in the appendix 2.

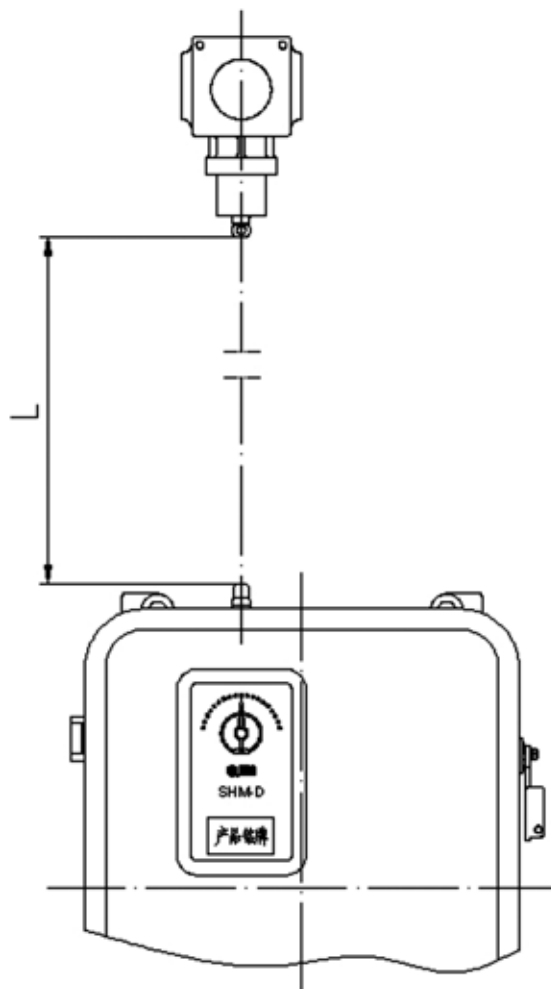

Drawing 2



Warning

Before connecting MDU with tap changer, please make sure they are set at same position.



Attention

The vertical inclination is no more than 2 degree. Use universal joint if necessary.

6.3 Adjustment of operation cycle

6.3.1 From the complete of diverter switch movement to the end of motor drive unit operation (around 1.5 or 2 grid)
You can adjust the gap by resetting the selector switch or diverter switch's movement. The marked center zone is the basis for adjustment.

6.3.2 One tap changer operation is a circle of the movement on the clock, namely 33 grids. Every grid stands for one hand crank operation. From operation's start to its complete the difference for two directional operations at both sides of marked zone shall be generally the same. Minor error is allowed.

6.3.3 Checking method

- a) Run the hand crank at one direction till the switch completes, record the circle
- b) Repeat this act at counter direction
- c) If there is difference between two directions, you need to adjust half of the difference and then connect it with tap changer.



Attention

Before this act, both MDU and tap changer shall be at set position



Warning

Only manual operation is allowed during this act. Make sure the MDU and tap changer operates at the same phase.



Attention

After putting hand crank inside the jack, you shall inject it into the bottom (8mm depth) to make sure the gear is into its position. You also need to push the hand crank hard enough to overcome the spring thrust.



Note

When operate the MDU fast by hand crank, stuck and sound will come out. It is normal because of step motor structure and it will not damage the MDU. Please slow down the manual operation speed to avoid the situation.

6.3.4 Case study

- a) The tap changer is at position 10, run the hand crank to 11 position till the diverter switch operates, record the pointer's location: seven grid to 6 o'clock, like 3.A.
- b) The tap changer is at position 11, run the hand crank to 10 position till the diverter switch operates, record the pointer's location: 1.5 grid to 6 o'clock, like 3.B.

Adjust value: $(7-1.5)/2=2.75$. You need adjust 3 grids

Method:

- a) Disconnect the vertical shaft
- b) Run the handcrank to 12 position for 3 grid
- c) Reconnect the vertical shaft
- d) Run the hand crank to 10 position till the diverter switch operates, record the pointer's location: 4.5 grid to 6 o'clock
- e) Check the counter direction's difference, result: 4 grid to 6 o'clock

Since the difference is within 1 grid, it is qualified.

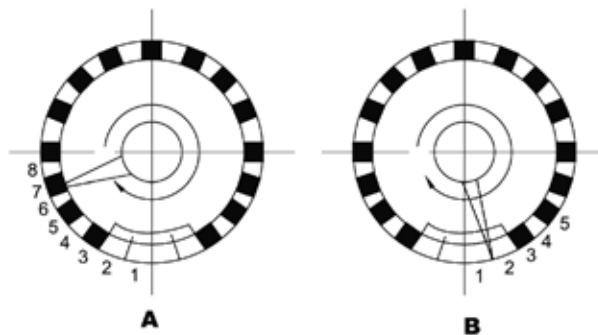

Drawing 3

6.4 MDU operation

6.4.1 Power supply inlet is on 3,5 of terminal X1, 200-240V/AC, 50/60Hz. Please refer to drawing 4.

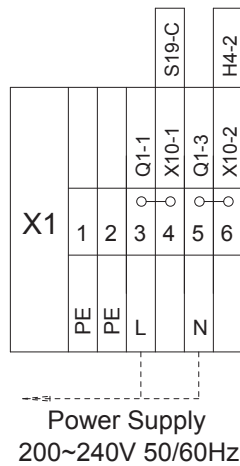

Drawing 4

6.4.2 The MDU is connected with controller SHM-K by optical fiber. After plug the fiber into the CX inlet, you can operate the MDU via controller., as shown in Drawing 5, 6.

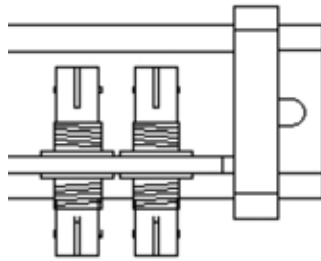

Drawing 5 CX inlet of MDU

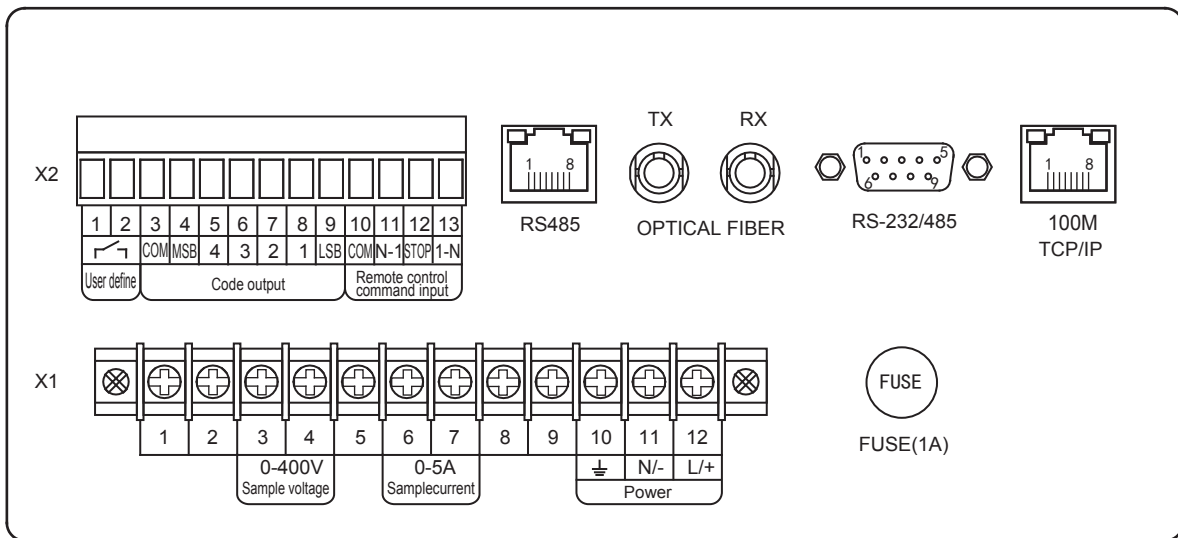

Drawing 6 SHM-K back panel



Warning

Min. bend radius for optical fiber during wiring or operation is R30 mm



Note:

The optical fiber inlet locates at the cabinet bottom, its diameter is 18.2mm, permanent joint along with the fiber, as shown in appendix 1



Note:









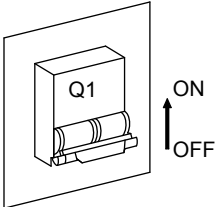

During the test or when remote control or automatic control is not required, MDU can operate by itself. Just input power supply as shown in 6.4.1 and choose local mode, you can operate MDU.

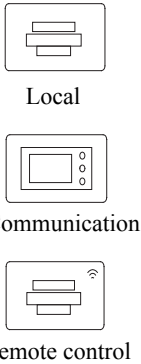

Note:

After operate the MDU, please read the operation instruction carefully especially appendix 3, appendix 4, appendix 5 and 6.4.3 to understand the function, operation method of above mentioned electrical components.

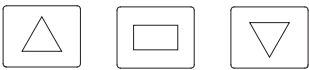
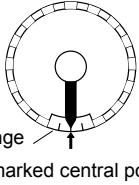
6.4.3 MDU operation instruction

1	Turn on Q1, energize step motor and local control panel, the status indication lamp will be on. Inspect whether the lamp and position indication of nixie tube is functional.	
2	Select the proper mode on the local control module. User can press 'raise', 'stop', and 'lower' button which locate on the local control module during selecting 'Local'  mode; SHM-K remote controller can work via optical fiber when 'Communication'  mode is selected; Remote control input terminal of MDU is added as a special design. Please select 'Remote control'  mode for controlling.	
3	The control buttons for local mode locate on the SHM-LC-S local module. Press ‘  ’, the motor drive unit raise one position. Press ‘  ’, the motor drive unit lower one position. Press ‘  ’, the motor drive unit stop the operation immediately.	
4	After rise or lower of every operation, the status indicates pointer shall rest within the operation complete range. The marked center pointers taken as the basis for adjustment.	
5	When you operate via the controller SHM-K, make sure the fiber is well connected. If it is connected alright, communication indication lamp CH2 will flicker. Otherwise, you have to interchange plugs of optical fibers. Follow the instruction of third item in this chapter after the communication resumes	SHM-LC-S local control panel 

6.5 Transportation



Note:

In case, the MDU is dissembled during transformer transportation. The installation shall follow instruction 6.1 -6.4



Attention:

In case, the MDU is transported with transformer by ocean(withstand the salt fog or tropical environment) Please wrap the MDU and drive shaft with plastic film to avoid long time exposure to the open air.

6.6 Maintenance

During the routine inspection for the transformer, please carry out following inspections on MDU as well.

Check sealing component on the cabinet

Check the appearance of internal components.

7. Appendix

Appendix 3 Internal component arrangement

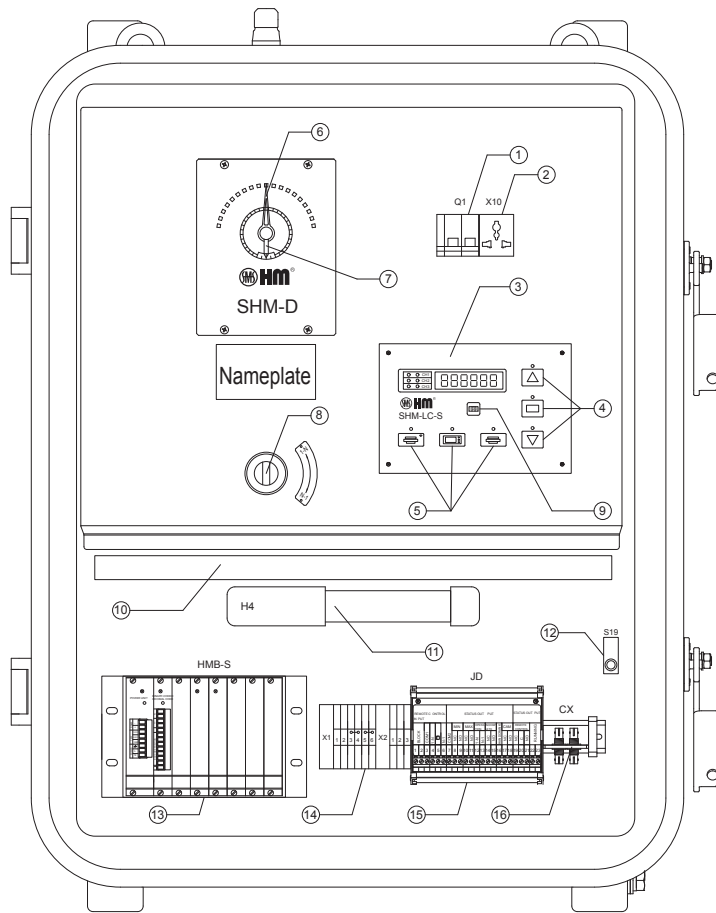

- 1 MICRO CIRCUIT BREAKER
- 2 AUXILIARY POWER SUPPLY SOCKET
- 3 LOCAL CONTROL MODULE
- 4 'RAISE', 'STOP', 'LOWER' BUTTON
- 5 'REMOTE', 'COMMUNICATION', 'LOCAL' BUTTON
- 6 POSITION INDICATION
- 7 TAP CHANGE INDICATION
- 8 SPIN AXIS FOR HAND CRANK
- 9 COUNTER KEY
- 10 WIRE SLOT
- 11 LAMP
- 12 DOOR SWITCH
- 13 POSITION SIGNAL OUTPUT MODULE
- 14 TERMINAL BLOCK
- 15 SIGNAL INPUT/OUTPUT INTERMEDIATE RELAY PLATE
- 16 OPTICAL FIBER INTERFACE

9 SHM-LC-S Operation counter instruction

	Press operation button then the counter start working and the result will be displayed on the nixie tube. It will turn back to non-counter status after few seconds.
--	--

3 SHM-LC-S local controller status instruction

Position	Status	Meaning	
Nixie tube (non-counter status)	Lowest three	Digit	Display tap changer current position
	Secondary	Δ	Motor drive unit is at Max. or Min. position
	Top	L	Block the motor drive unit. No further operation.
		d	Motor fault
		H	Hand crank inserted and motor operation forbidden
	Communication instruction lamp	E-01	Motor drive unit is not at the proper position
		E-02	Configuration fault or error
E-03		Variable of before and after operation of position sensor abnormal	
E-04		No or invalid position sensor	
Communication instruction lamp	CH1	Light flash	Send position signal
	CH2	Flash	Communicating with remote controller
	CH3	Flash	Communicating with debugging interface

5 SHM-LC-S 'local', 'remote control', 'communication' instruction

	Remote control input terminal of MDU is added as a special design. Controlled by external signal and please refer to the specific drawing.
	Controlled via optical fiber
	User can press 'raise', 'stop', and 'lower' button which locate on the local control module

4 SHM-LC-S local mode button instruction

	Raise position
	Stop
	Lower position



Attention:

When you operate via the controller SHM-K, make sure the fiber is well connected. If it is connected alright, communication indication lamp CH2 will flicker. Otherwise, you have to interchange plugs of optical fibers.



Note:

No. 1, 2 of terminal X2 is for over-current blocking input, they are N/O type contact. When contacts close, MDU will be blocked.

Appendix 4 Local control panel arrangement

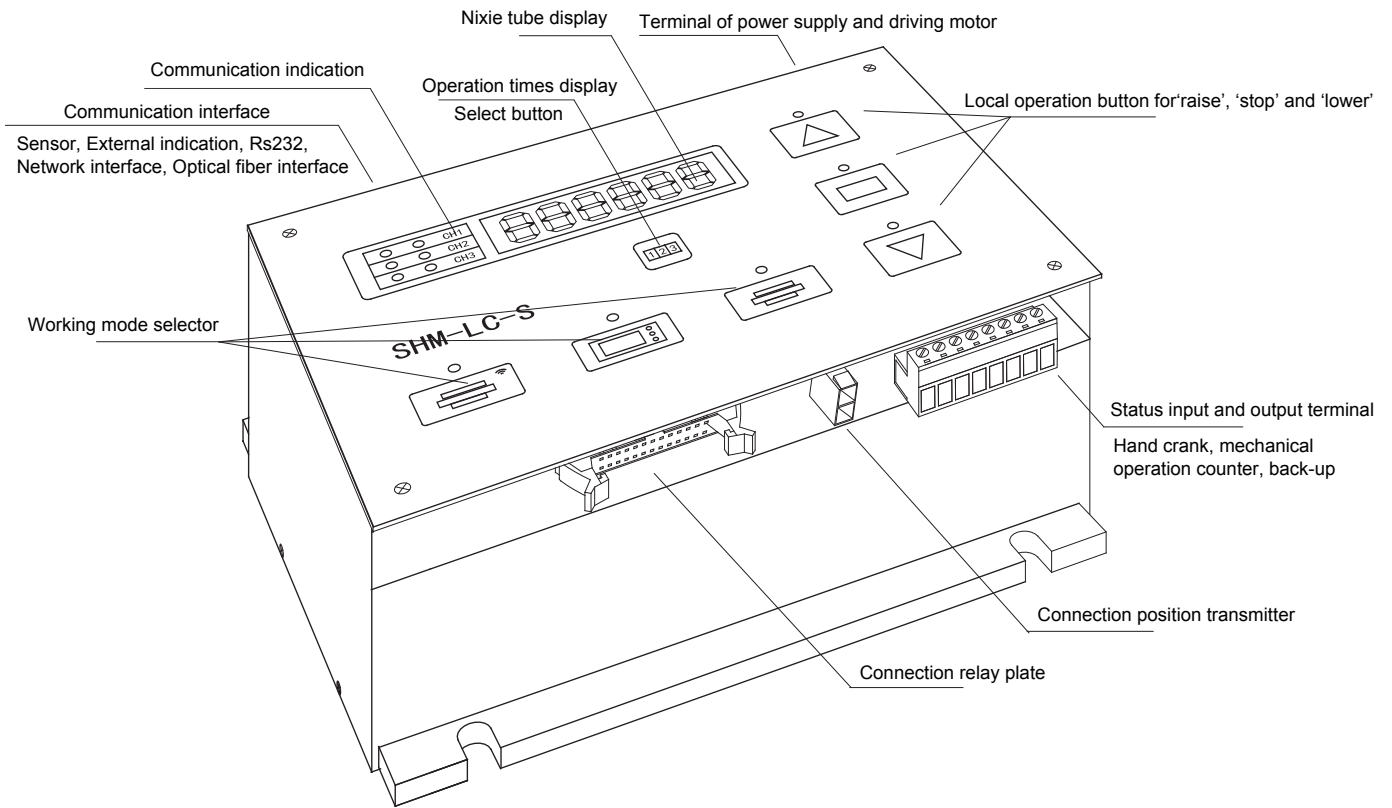

Appendix 5 Electrical diagram of SHM-D

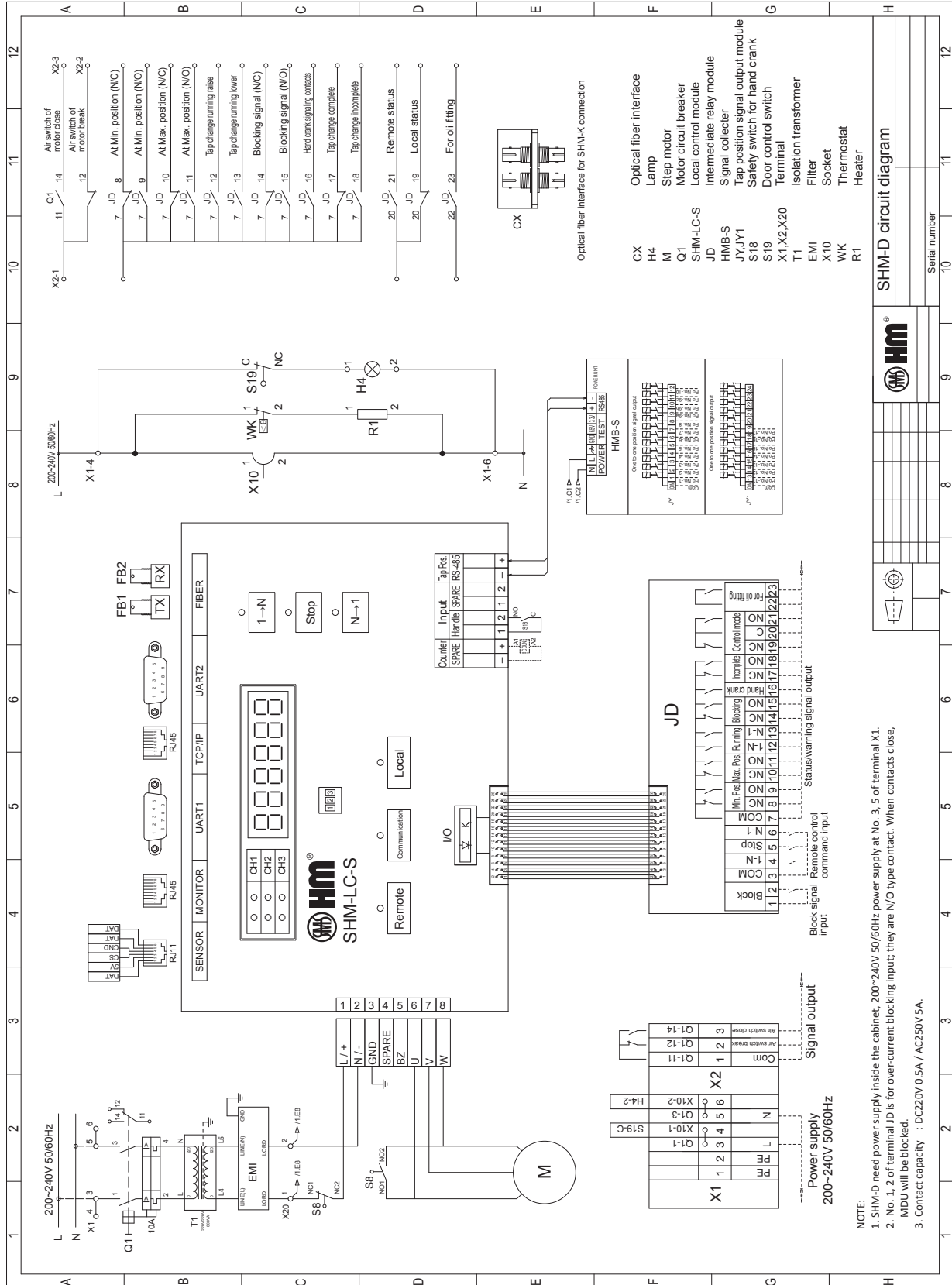

NOTE:

- SHM-D need power supply inside the cabinet, 200~240V 50/60Hz power supply at No. 3, 5 of terminal X1.
- No. 1, 2 of terminal JD is for over-current blocking input; they are N/O type contact. When contacts close, MDU will be blocked.
- Contact capacity : DC220V 0.5A / AC250V 5A.

Appendix 6 SHM-K controller dimension.

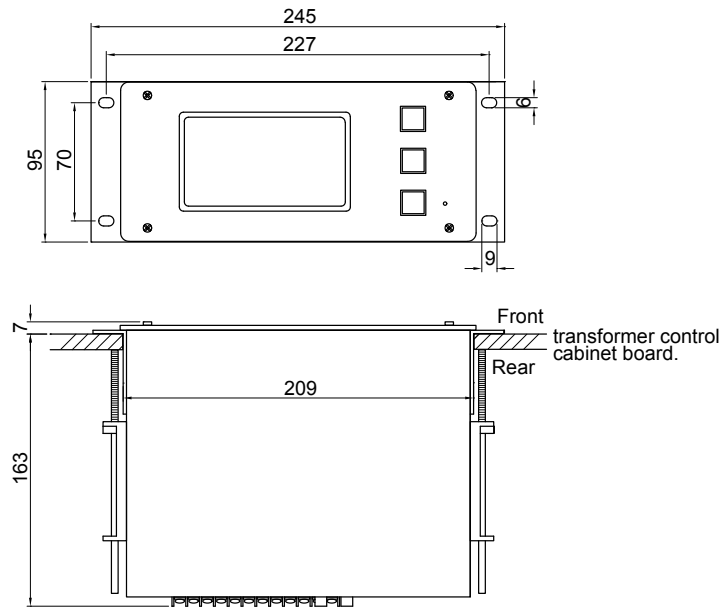

NOTE:

The controller can be fixed either by screwing the bolt at front board or fastening the bayonet pin on each side as shown in above picture.

Size: 210mm x 96mm (Length x width)

Shanghai Huaming Power Equipment Co., Ltd.

Address: No 977 Tong Pu Road, Shanghai 200333, P.R.China

Tel: +86 21 5270 3965 (direct)

+86 21 5270 8966 Ext. 8688 / 8123 / 8698 / 8158 / 8110 / 8658

Fax: +86 21 5270 2715

Web: www.huaming.com

E-mail: export@huaming.com